

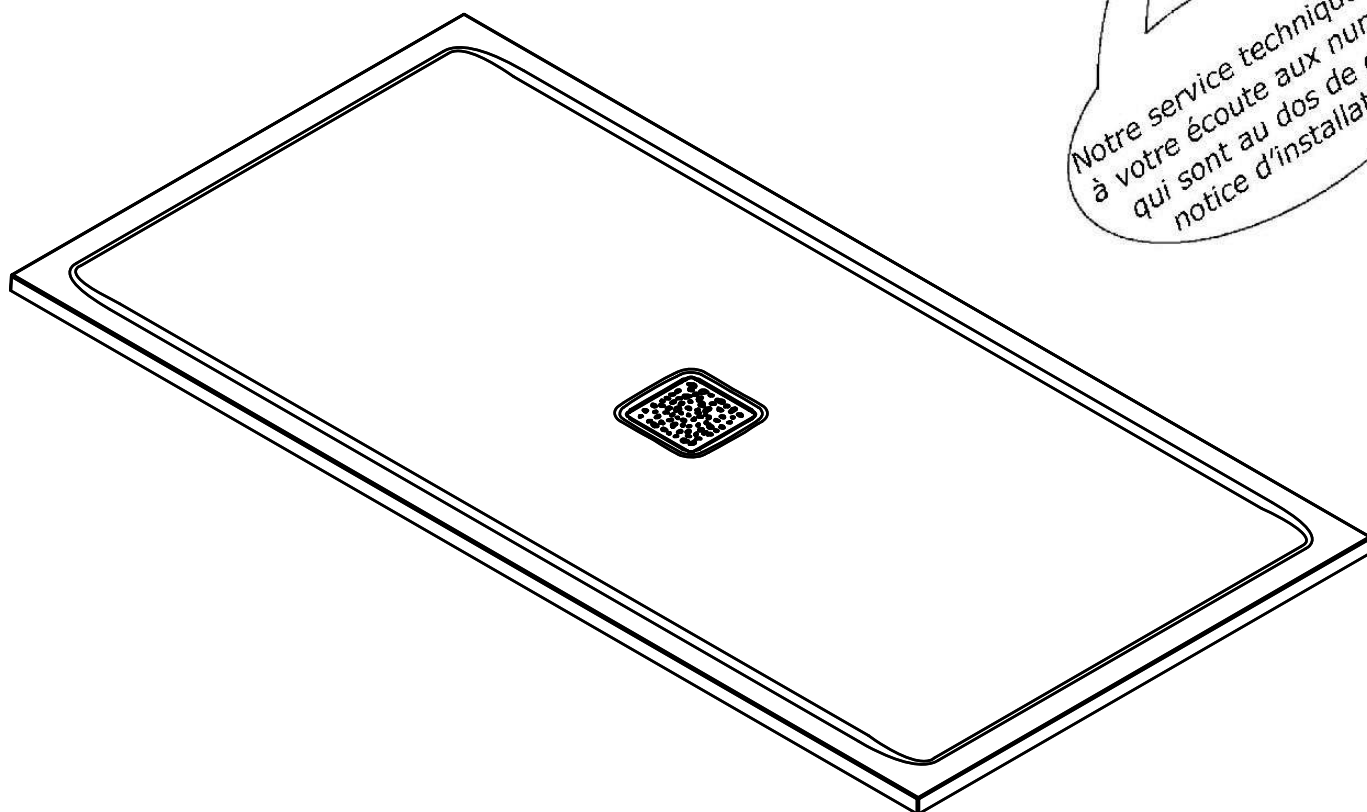

- F Notice de montage ● GB Installation instructions
- E Manual de instalación ● I Istruzioni di montaggio
- NL Montage-instructies ● D Montageanleitung





- F Attention aux étapes :
- GB Check installation steps :
- E Atención a los pasos :
- I Attenzione ai passi :
- NL Aandacht voor de stappen :
- D Achtung vor den Schritten :

P. 7 - 32 - 33

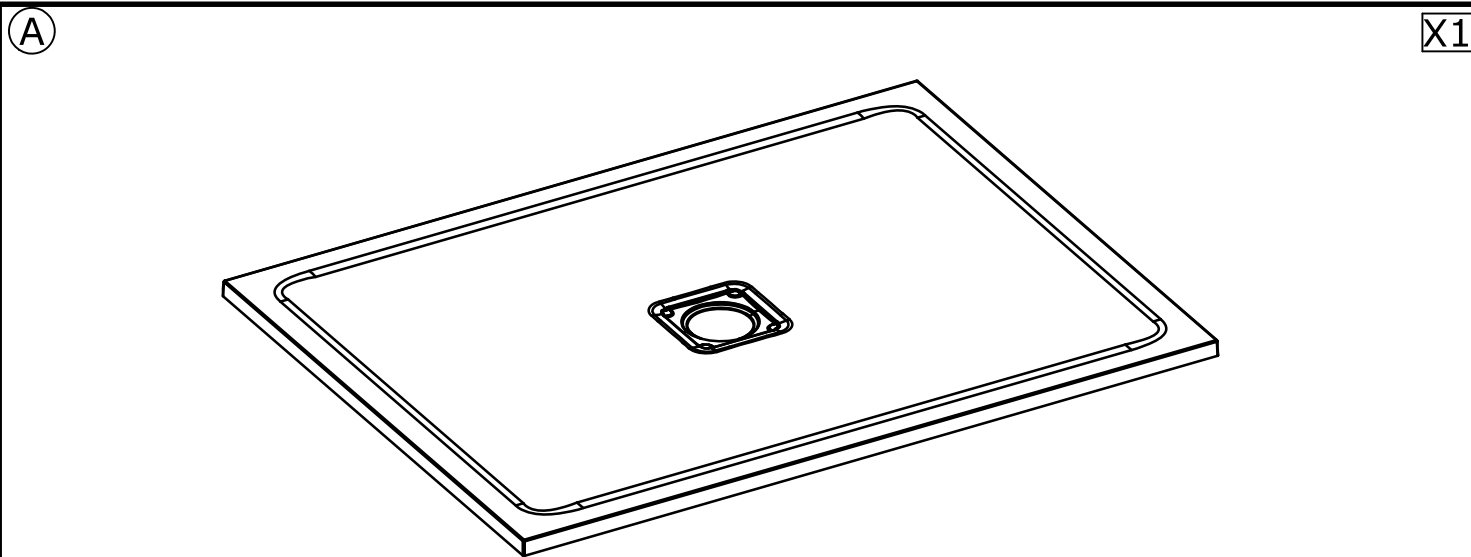

	100x70	REC640	120x70	REC643	140x70	REC647	160x80	REC650			
90x75	REC638	100x80	REC641	120x80	REC644	140x80	REC648	160x90	REC651	180x80	REC653
90x90	REC639	100x90	REC642	120x90	REC645	140x90	REC649	170x70	REC652	180x90	REC654

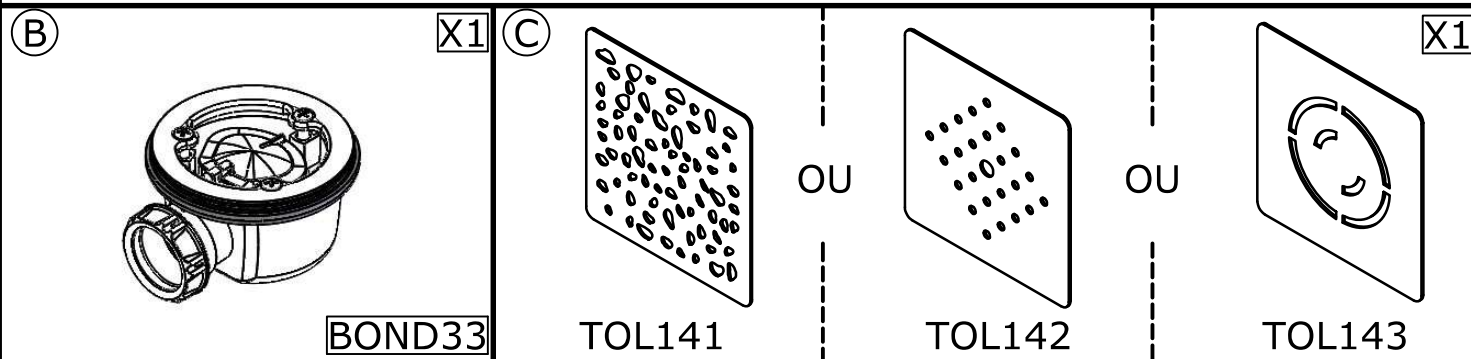

- Ⓐ Les quantités données sont les quantités utiles au montage. les sachets fournis contiennent des pièces supplémentaires.
- Ⓑ The quantities given are what are required for the installation. There may be some surplus in the package provide.
- Ⓒ Las cantidades indicadas son las cantidades necesarias para el montaje. Las bolsitas incluidas contienen piezas suplementarias.
- Ⓓ Le quantità fornite sono le quantità necessarie al montaggio. I sacchetti forniti contengono pezzi supplementari.
- Ⓔ De aangegeven aantallen zijn bestemd voor de montage. De bijgeleverde zakjes bevatten extra onderdelen
- Ⓕ Die Mengenangaben beziehen sich auf die für die Montage benötigten Teile. Es kann eine gewisse Überzahl an Teilen in der Packung vorhanden sein.



- Ⓕ "Le montage de ce receveur avec une autre bonde que celle fournie annule la garantie, sauf KINEFLOOR, BOND19 et BOND25 de notre catalogue"
- Ⓖ "Mounting this receiver with a bung other than the one provided voids the warranty, except for KINEFLOOR, BOND19 and BOND25 in our catalogue"
- Ⓖ "El montaje de este plato de ducha con un tapón distinto al suministrado anula la garantía, excepto para KINEFLOOR, BOND19 y BOND25 en nuestro catálogo".
- Ⓖ "Il montaggio di questo ricevitore con un tappo diverso da quello fornito invalida la garanzia, ad eccezione di KINEFLOOR, BOND19 e BOND25 nel nostro catalogo".
- Ⓖ "Deze douchebak monteren met een andere dan meegeleverde sifon doet de garantie vervallen, met uitzondering van de KINEFLOOR, BOND19 en BOND25 uit onze catalogus".
- Ⓖ "Die Montage der Duschtasse mit einer anderen Ablaufgarnitur als der werksseitig vorgesehenen führt zum Erlöschen der Garantie. Ausgenommen hiervon sind die Abläufe: KINEFLOOR, BON19 und BOND25 aus unserem Katalog".

F Matériel nécessaire GB Tools required E Material necesario  
 I Materiale necessario NL Benodigdheden D Erforderliche Werkzeuge

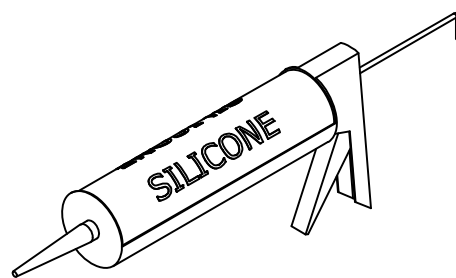
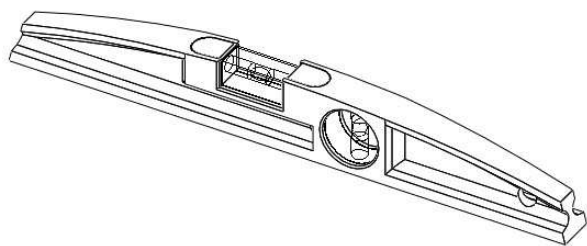

- F Colle polyuréthane ou MS polymère
- GB Polyurethane adhesive or MS polymer
- E Pegamento poliuretano o polímero MS
- I Colla poliuretana o MS polimero
- NL Polyurethaan of MS-polymeer lijm
- D Polyurethan oder MS-Polymere Montagekleber verwenden

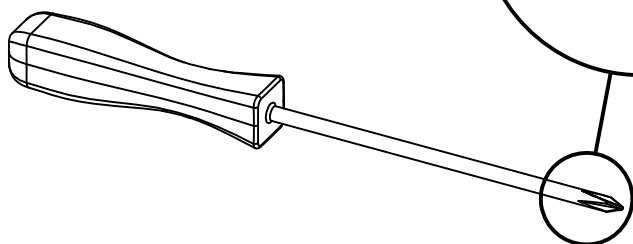
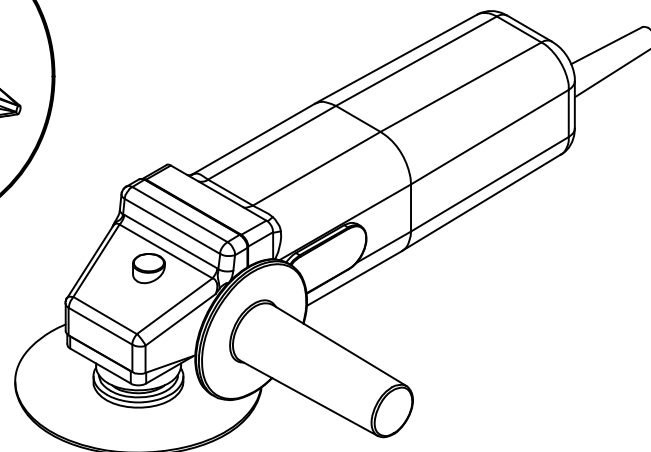
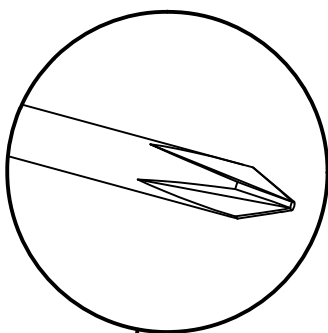
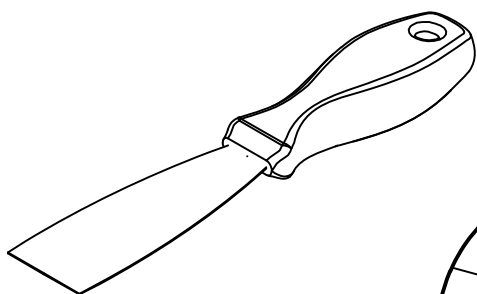

- F Meuleuse avec lame diamant Ø230mm min.
- GB Grinder with diamond blade Ø230mm min.
- E Pulidora con disco diamantado Ø230mm min.
- I Mola con lama diamantata Ø230mm min.
- NL Flexmachine met diamanten slijpsteen Ø230mm min.
- D Winkelschleifer mit Diamanttrennscheibe Ø230mm min.



- F DECOUPE OPTIONNELLE DU RECEVEUR
- GB ZONE AVAILABLE FOR OPTIONAL RECUTTING
- E RECORTE OPCIONAL
- I TAGLIO OPZIONALE DEL PIATTO
- NL BIJSNIJDEN VAN DE DOUCHEBAK, OPTINEEL
- D OPTIONALE SCHNEIDBEREICHE DER DUSCHWANNE

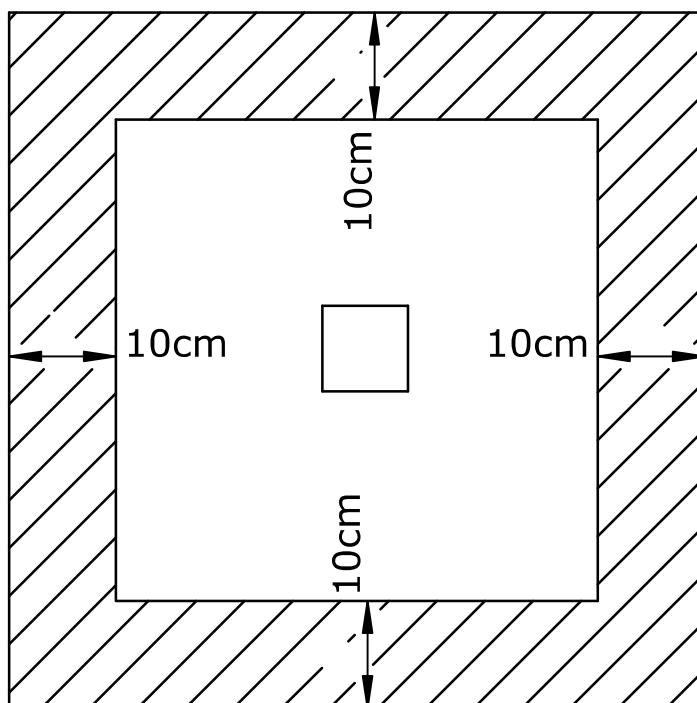
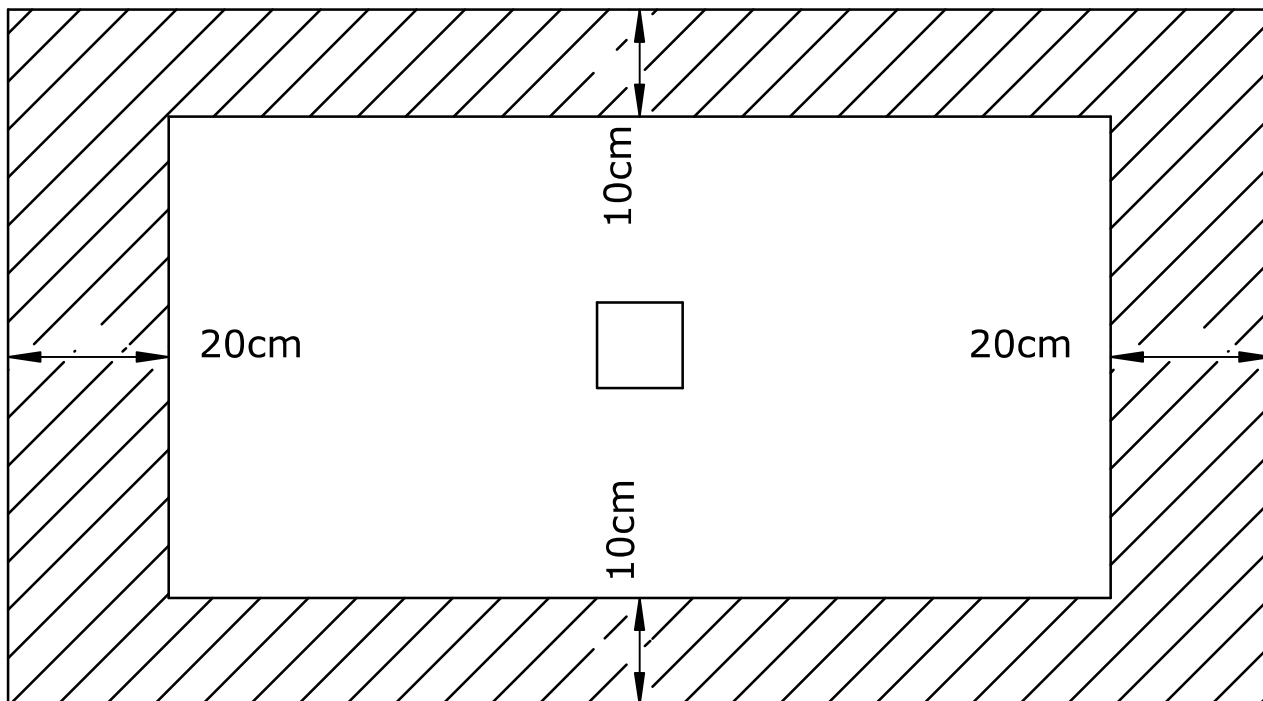

- F Zone MAXI découpable
- D MAX cuttable area
- E Zone MAXIMA de recorte
- I Limite MASSIMO di taglio
- NL MAXIMAAL aanpasbaar deel
- D MAXIMALER Schneidbereich

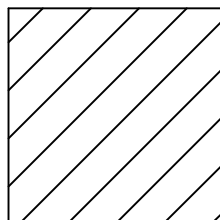

1

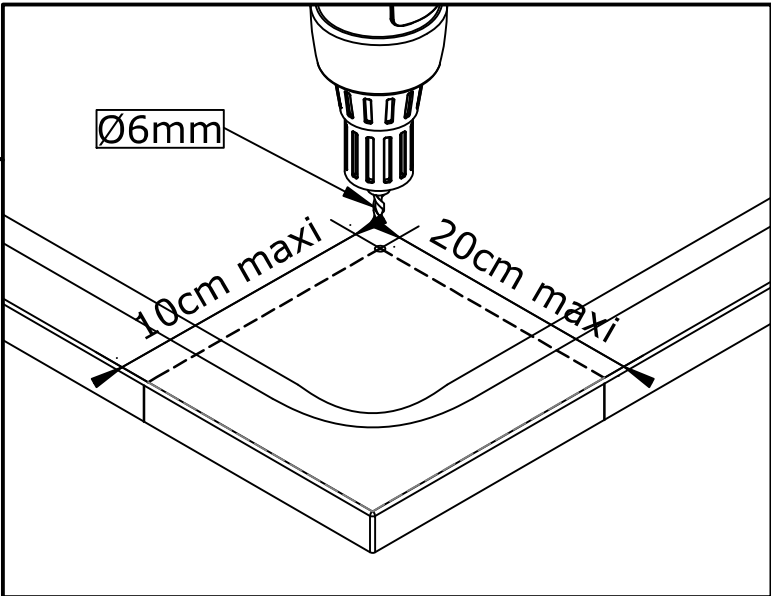
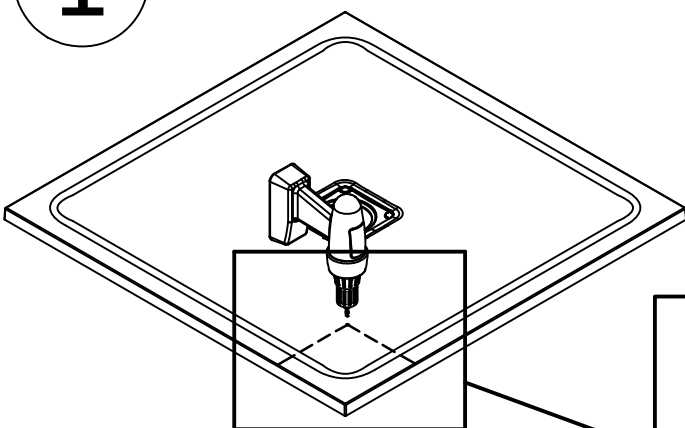

2

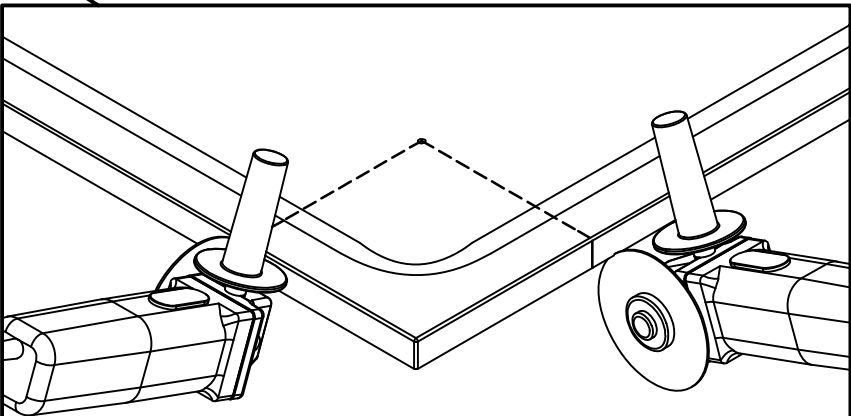
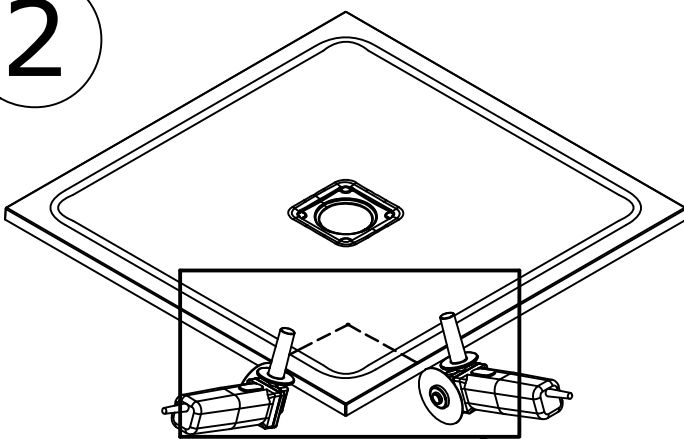

3



●**F**-Appliquer une couche de colle polyuréthane ou MS polymère à l'aide d'une spatule sur la surface coupée et combler l'espace entre les nervures du receveur avec une couche de mortier adhésif.

●**GB**-Apply a polyurethan adhesive or MS polymer layer using a spatula over the raw surface and fill the space between the ribs of the tray with a layer of adhesive mortar.

●**E**-Aplicar una capa de pegamento poliuretano o polímero MS en la superficie recortada. Puede ayudarse de una espátula y rellenar los espacios huecos del plato con una capa de mortero adhesivo.

●**I**-Applicare della colla poliuretanică o MS polimero con l'aiuto di una spatola sulla parte tagliato e compensare lo spazio tra le venature del piatto con uno strato di materiale adesivo.

●**NL**-Breng met een spatel een laag polyurethaan lijm of MS polymeer lijm aan op de zaagranden, en vul de tussenliggende ruimte met het steunoppervlak van de douchebak op met een laag cement.

●**D**-Wenn Sie ihre Duschtasse zuschneiden, müssen die Schnittkanten mittels Polyurethan- oder MS-Polymer-Klebstoff versiegelt werden. Tragen Sie die Versiegelung mit einem Spachtel auf der Schnittfläche bis unterhalb der Duschtasse auf.

- F** Colle polyuréthane/MS polymère
- GB** Polyurethane adhesive/MS polymer
- E** Pegamento poliuretano/polimero MS
- I** Colla poliuretanică/MS polimero
- NL** Polyurethaan/MS polymeer lijm
- D** Schicht aus Polyurethan-/MS-Polymer-Klebstoff

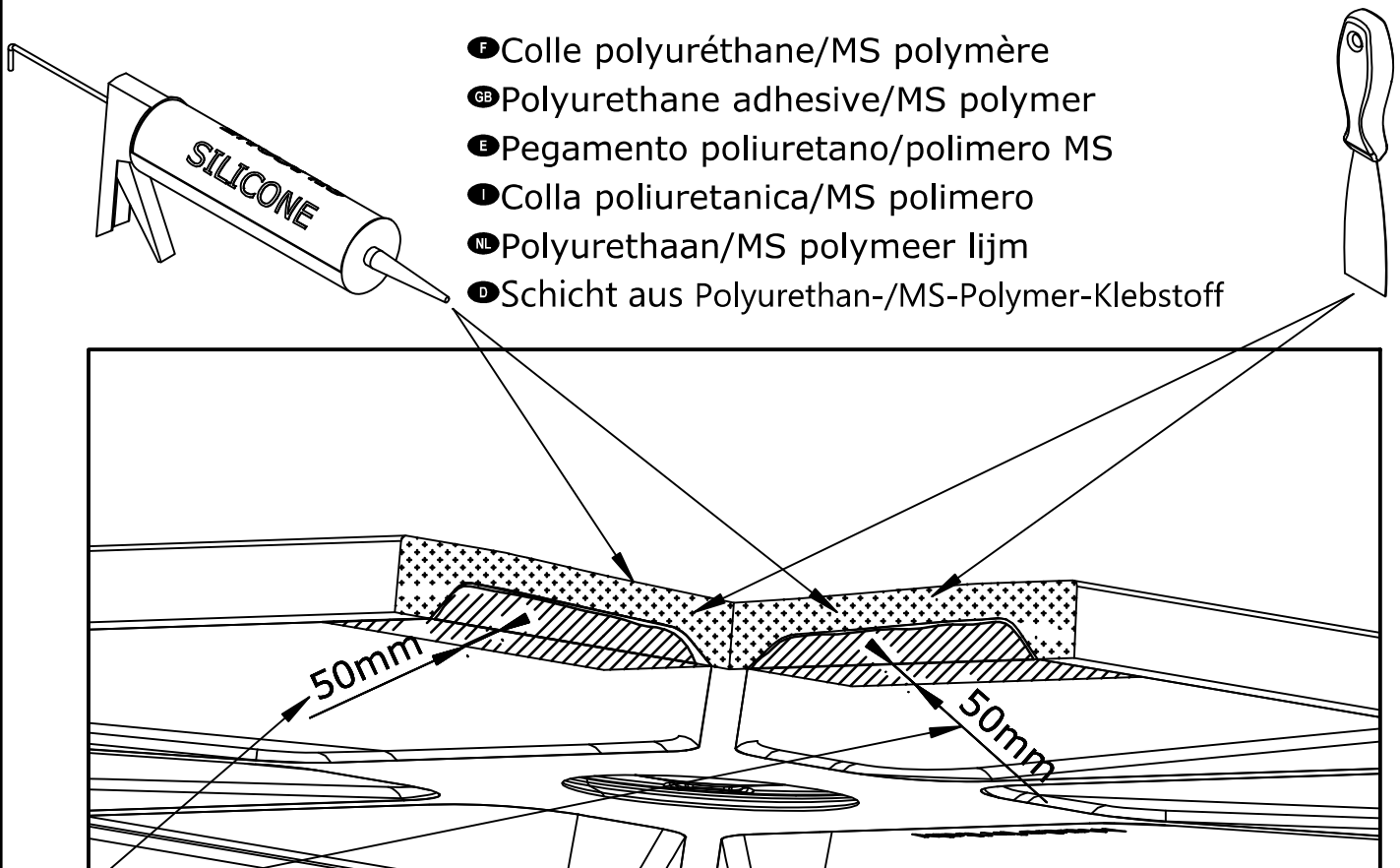

- F** Couche de 50mm de mortier adhésif ●**GB** 50mm layer of adhesive mortar
- E** Capa de 50mm de grosor de mortero adhesivo
- I** Strato di 50mm di materiale adesivo
- NL** Laag van 50mm cement ●**D** 50 mm Versiegelung auftragen

- F Nombre de pieds ● GB Feet quantity ● E Cantidad de pies  
 ● I Quantità di piedini ● NL Hoeveelheid voeten ● D Anzahl an Füße

90x75	4	90x90	4		
100x70	4	100x80	4	100x90	4
120x70	8	120x80	8	120x90	8
140x70	10	140x80	10	140x90	10
160x80	10	160x90	10		
170x70	10				
180x80	12	180x80	12		

● F La distance bord à bord entre deux pieds ne doit pas être de plus de 30 cm.  
LES PIEDS DOIVENT ETRE INSTALLES SUR LES NERVURES DU RECEVEUR.

● GB The distance from the edge of the shower tray to the edge of a peripheral support should be no more than 30 cm.  
THE FEET MUST BE INSTALLED ON THE SHOWER TRAY RIBS.

● E La distancia entre cada pie no debe superar los 30 cm.  
LOS PIES DEBEN ESTAR INSTALADOS SIGUIENDO LAS NERVIOS DEL PLATO.

● I La distanza tra due piedi non dovrebbe essere superiore a 30 cm.  
I PIEDI DEVONO ESSERE INSTALLATI SULLE NERVATURE DEL PIATTO DOCCIA.

● NL De afstand tussen twee stelpoten mag niet meer dan 30 cm bedragen.  
DE STELPOTEN DIENEN OP HET STEUNOPPERVLAK VAN DE DOUCHEBAK GEÏNSTALLEERD TE WORDEN.

● D Der Abstand zwischen zwei verstellbaren Füßen darf 30 cm nicht überschreiten.  
DIE FÜßE MÜSSEN AUF DEN TRÄGERN DER DUSCHTASSE MONTIERT WERDEN.

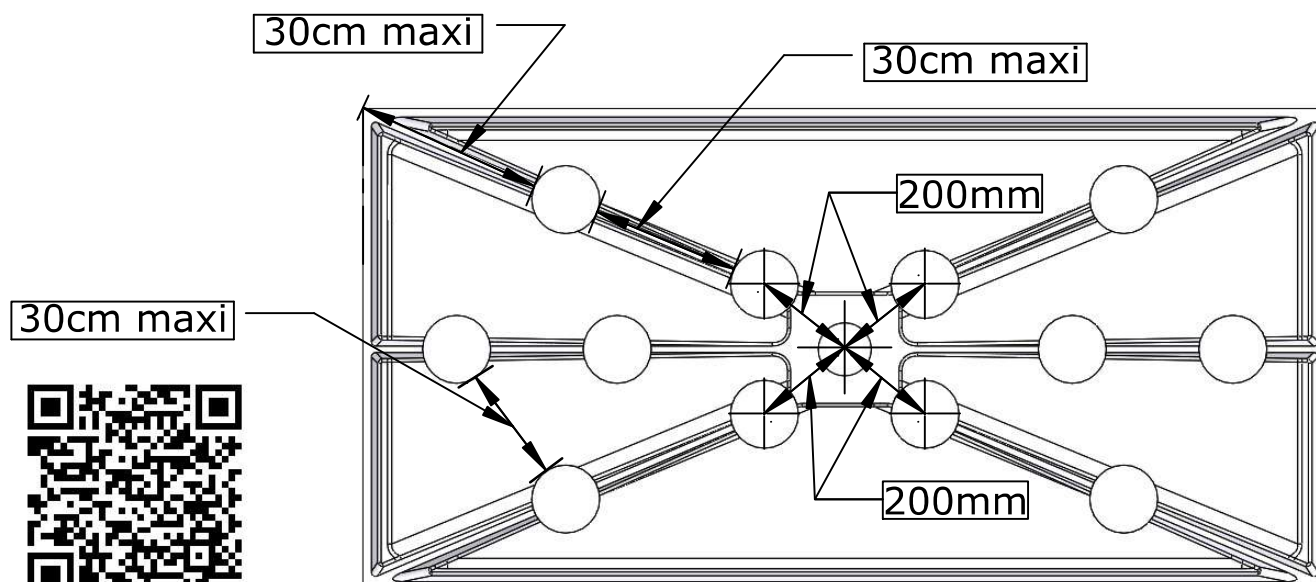

Scan me

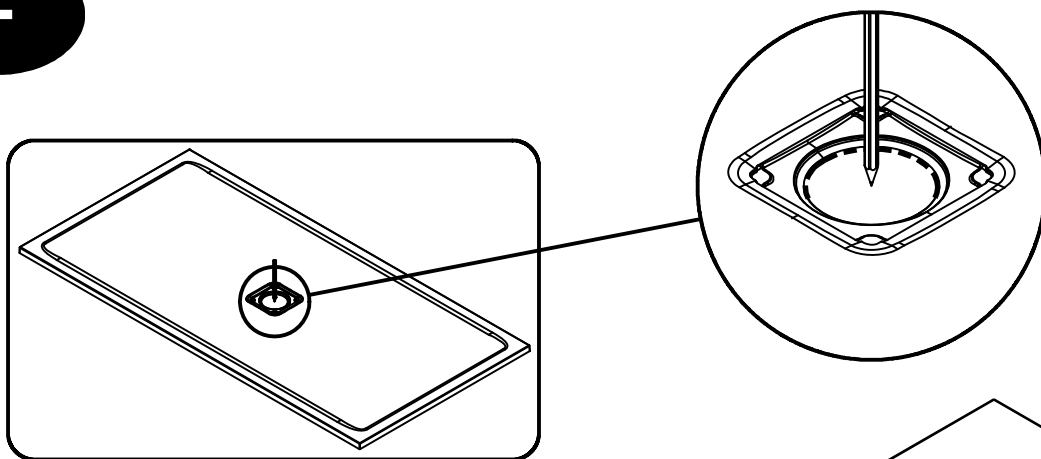

Tracer la position de la bonde et réaliser un montage à blanc de la bonde et du receveur



- ① - silicone de finition traité antifongique de 5mm de largeur minimum
- ② - silicone d'étanchéité souple traité antifongique
- ③ - élément de soutien du joint silicone
- ④ - silicone d'appui
- ⑤ - colle polyuréthane ou MS polymère

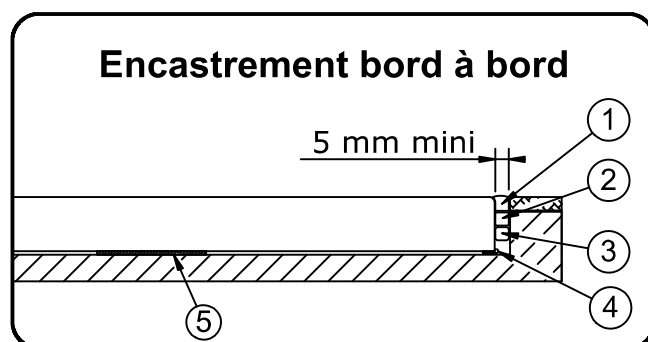
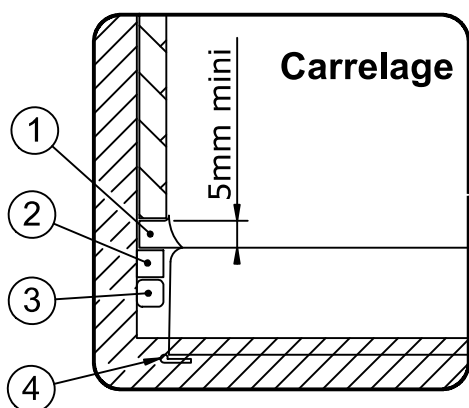



Pendant toute la durée des travaux, protéger le receveur contre toute agression : brûlures, chocs, rayures, décapants...



Le montage d'une soupape anti-vide est nécessaire pour une utilisation optimale si un autre appareil sanitaire est raccordé sur la même évacuation.

Ne pas utiliser d'acide chlorhydrique ni de dégraissant puissant

### Pose directe au sol

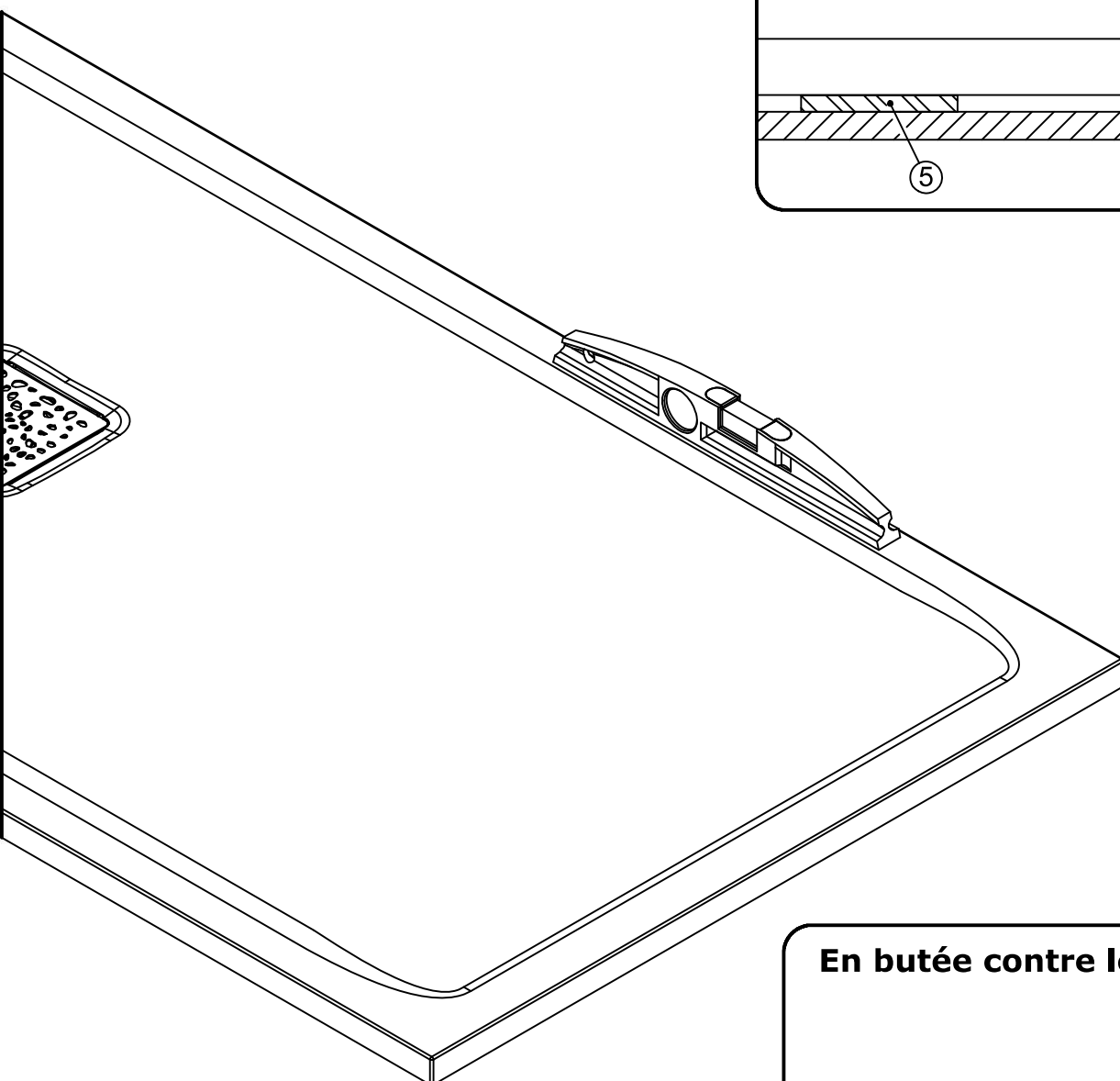
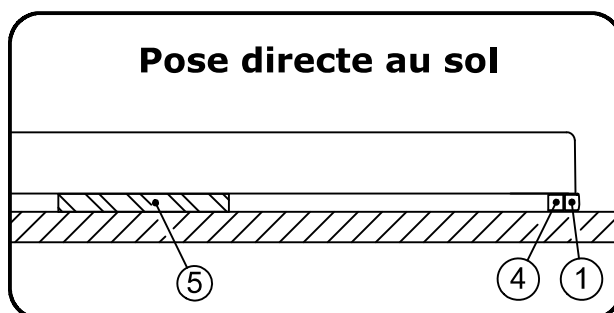

Sol rigide, plan et non humide indispensable

### En butée contre le carrelage

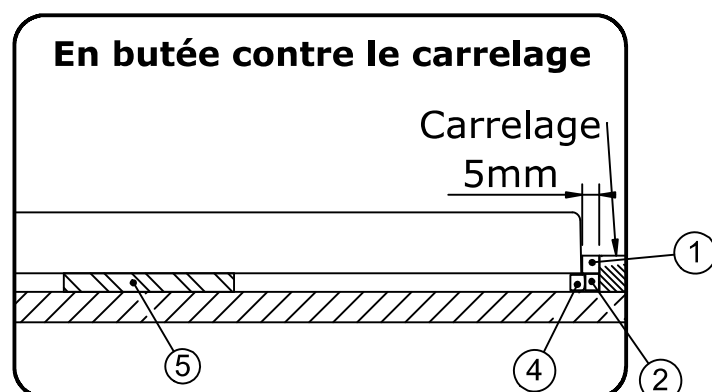

# TYPES D'INSTALLATION KINEMOON

## KINEMOON CARRÉ

### 1. Posé sur pieds réglables avec habillage carrelé

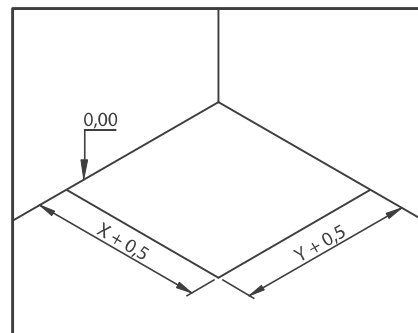
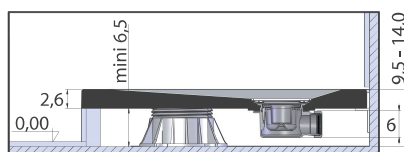
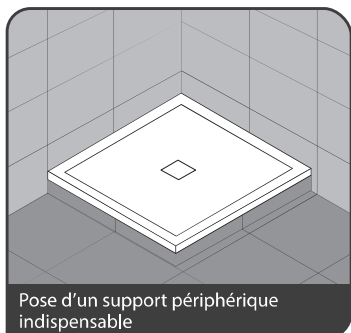

Préparation de l'implantation

### 2. Posé en butée contre le carrelage

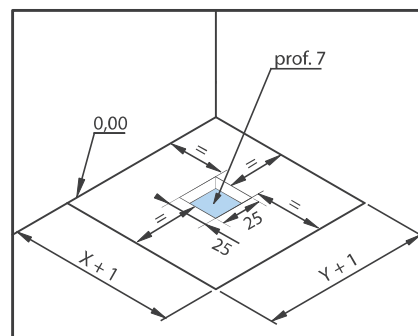
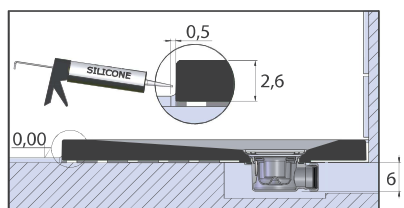
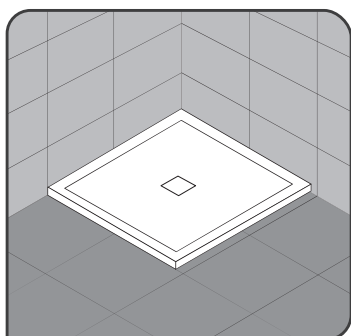

Préparation de l'implantation

### 3. Encastré et posé sur pieds réglables

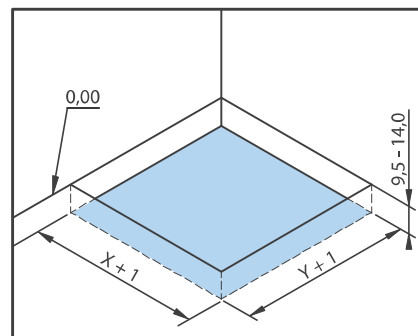
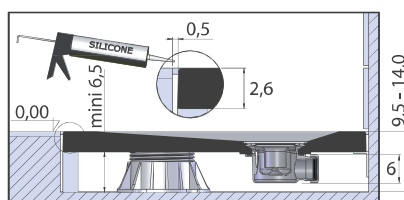
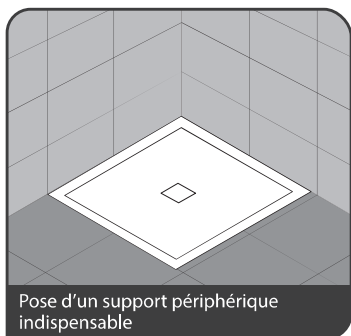

Préparation de l'implantation

### 4. Encastré et posé sans pieds réglables

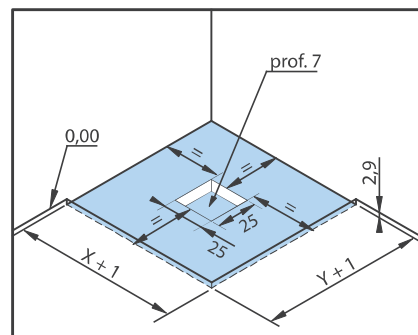
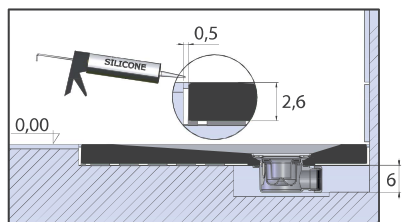
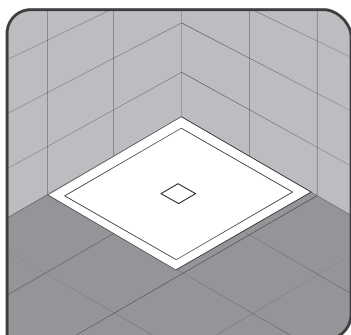

Préparation de l'implantation

# TYPES D'INSTALLATION KINEMOON

## KINEMOON RECTANGULAIRE

### 1. Posé sur pieds réglables avec habillage carrelé

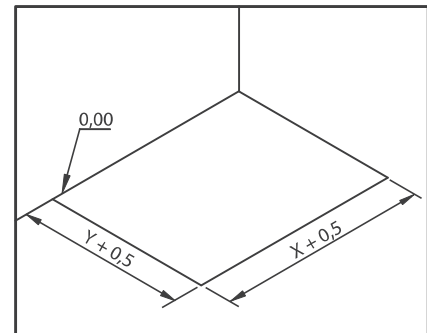
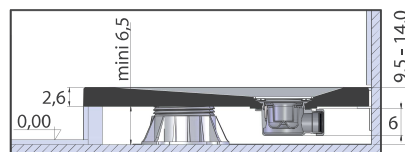

Préparation de l'implantation

### 2. Posé en butée contre le carrelage

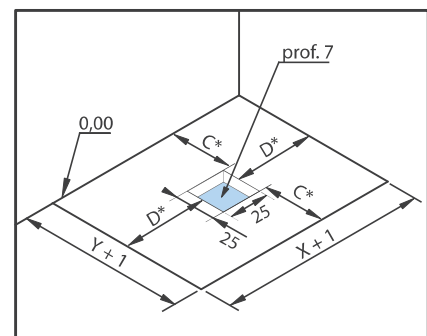
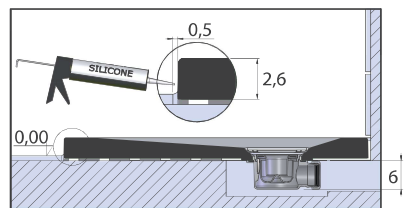
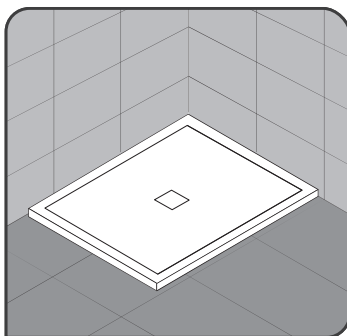

Préparation de l'implantation

### 3. Encastré et posé sur pieds réglables

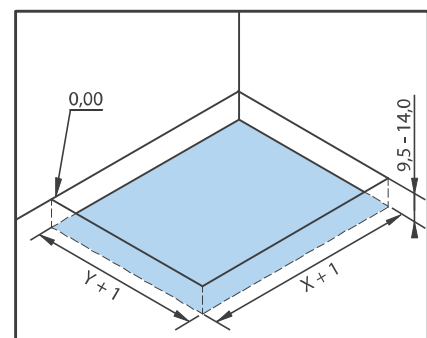
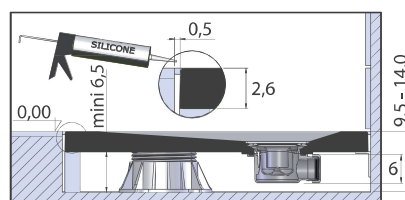

Préparation de l'implantation

### 4. Encastré et posé sans pieds réglables

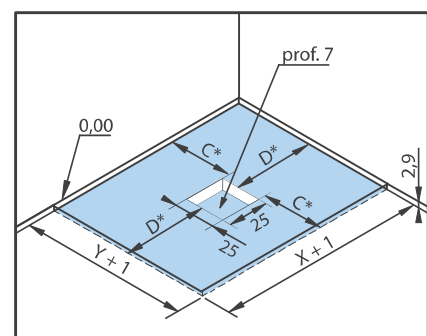
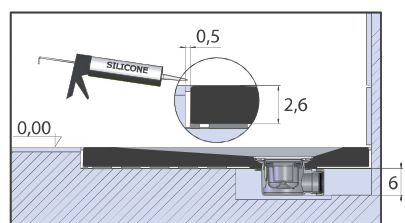
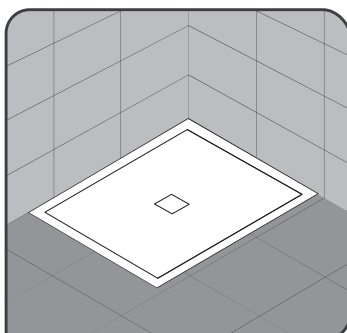

Préparation de l'implantation

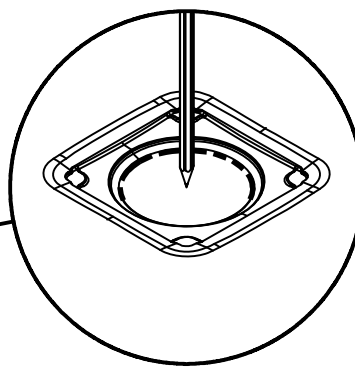
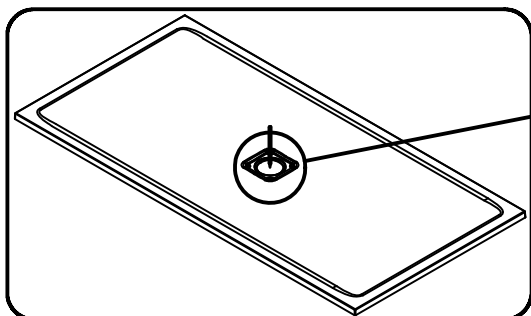

Mark the position of the waste and test-assemble the tray and waste

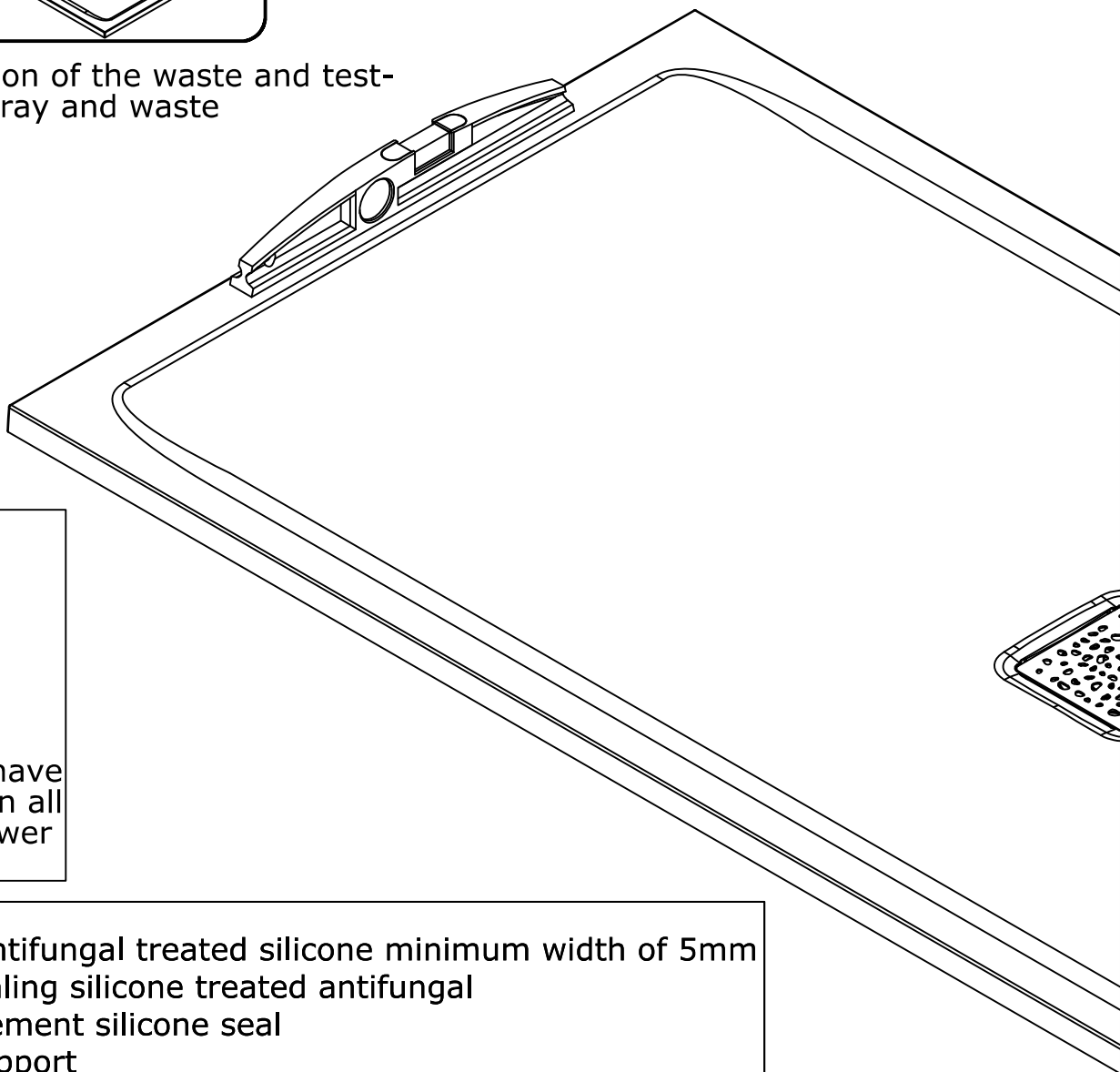

- ① - finishing antifungal treated silicone minimum width of 5mm
- ② - flexible sealing silicone treated antifungal
- ③ - support Element silicone seal
- ④ - silicone Support
- ⑤ - polyurethane adhesive or MS polymer

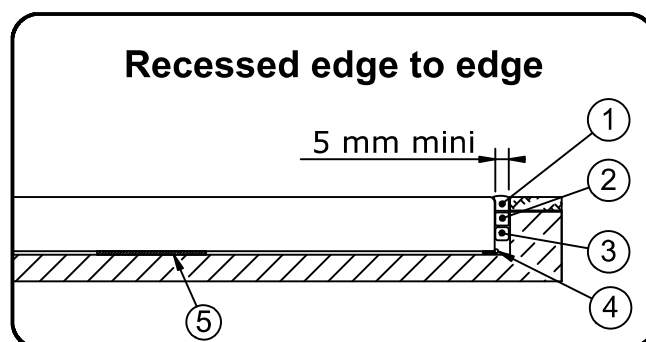
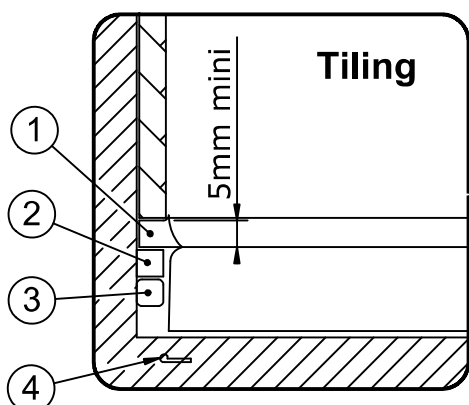



Throughout the protect the tray of the work, protect the recipient against any aggression: burns, shock, scratches, strippers ...



Mounting a vacuum relief valve is required for use optimal if another fixture is connected to the same drain.

Do not use hydrochloric acid or powerful degreaser

### Direct floor installation

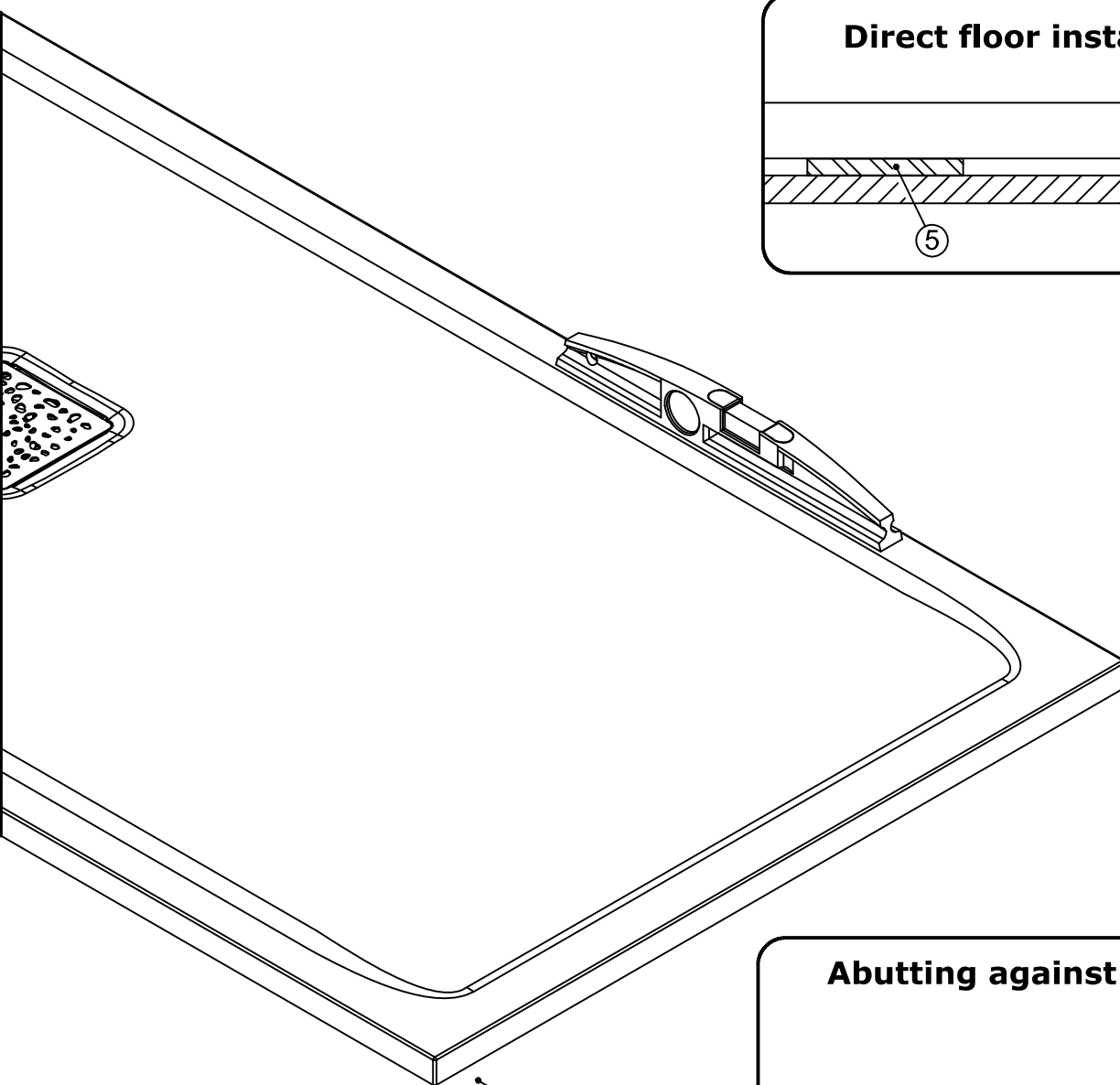
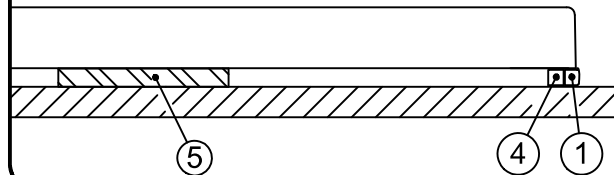

The base must be rigid, flat and dry

### Abutting against the tile

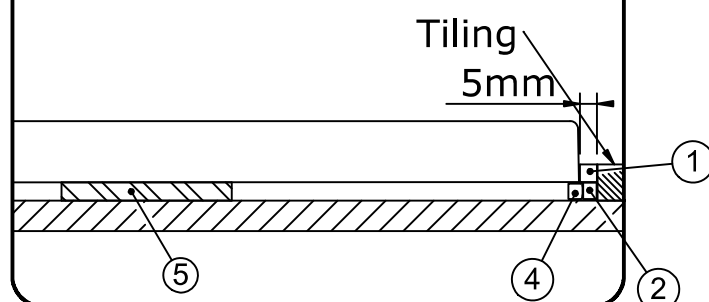

# KINEMOON INSTALLATION TYPES

## KINEMOON SQUARE

### 1. Mounted on adjustable legs with tiled cladding

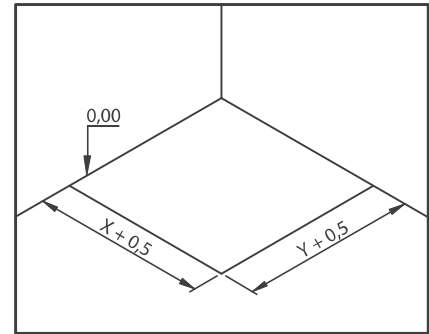
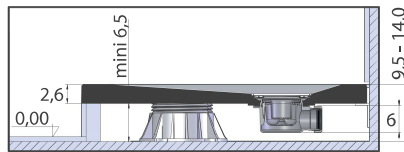
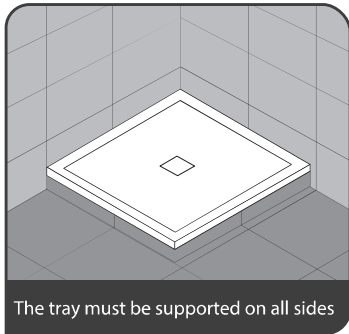

pre-installation

### 2. Installed in abutment against the tile

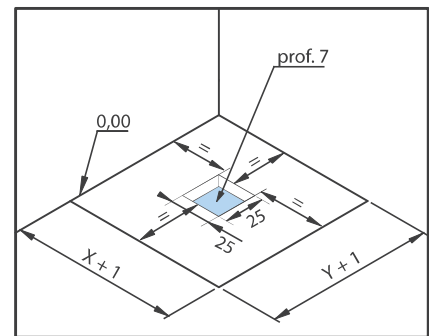
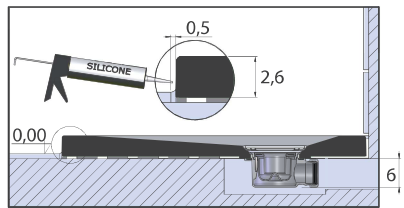
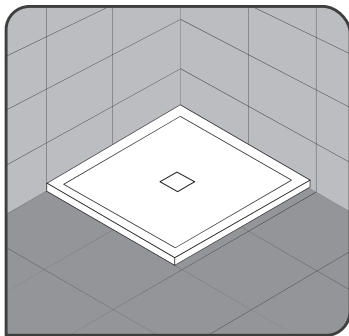

pre-installation

### 3. Built-in and placed on adjustable legs

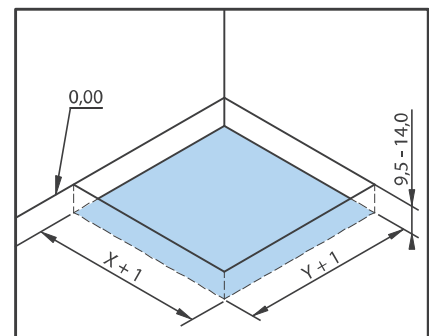
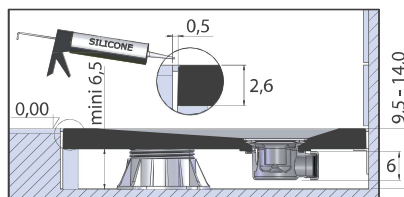
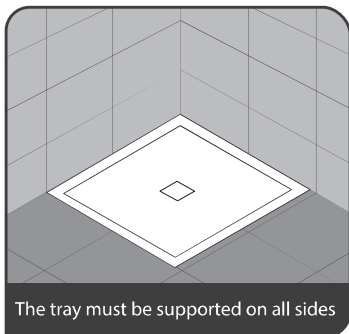

pre-installation

### 4. Built-in and installed without adjustable feet

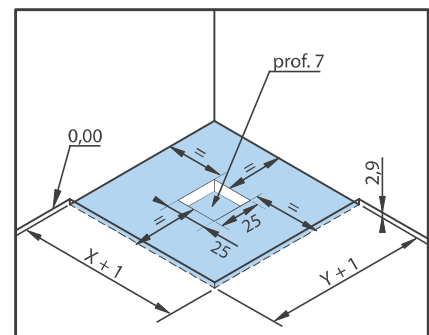
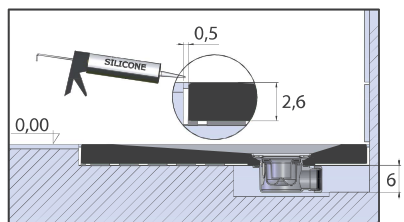
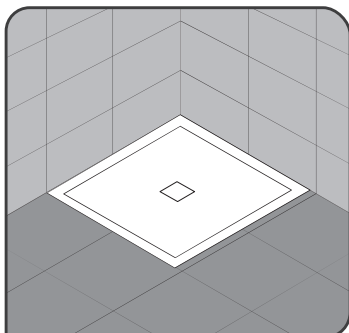

pre-installation

# KINEMOON INSTALLATION TYPES

## KINEMOON RECTANGULAR

### 1. Mounted on adjustable legs with tiled cladding

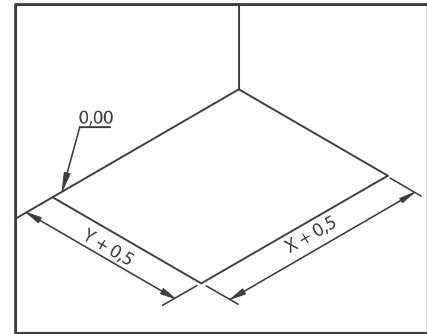
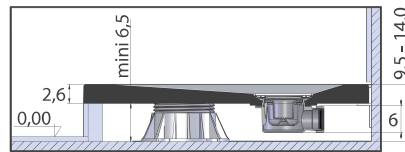
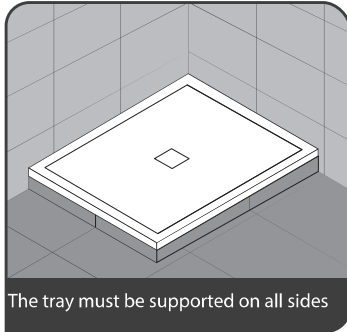

pre-installation

### 2. Installed in abutment against the tile

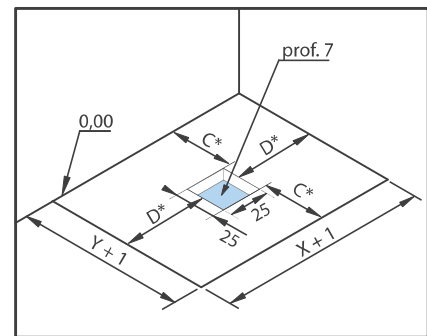
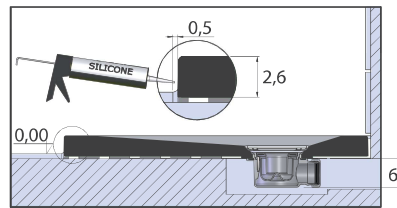
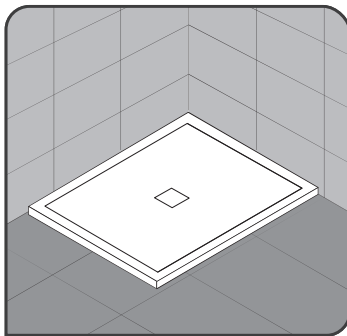

pre-installation

### 3. Built-in and placed on adjustable legs

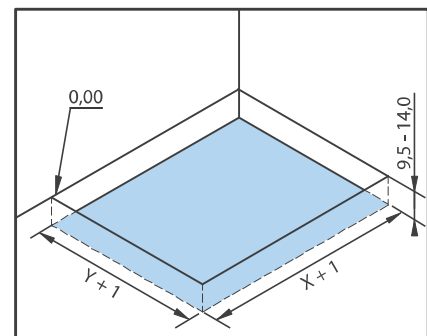
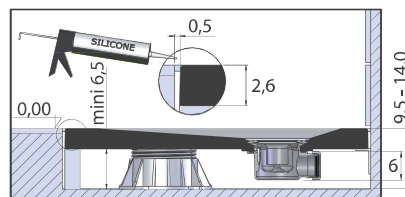
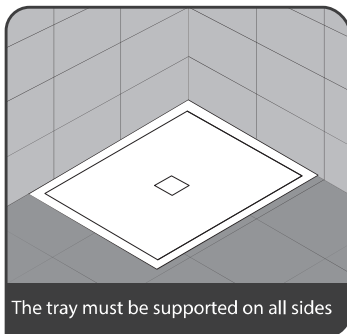

pre-installation

### 4. Built-in and installed without adjustable feet

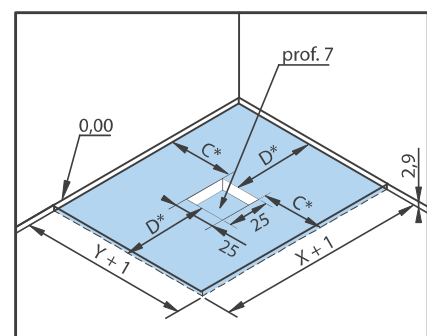
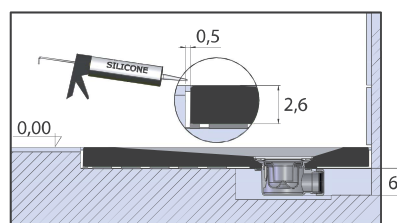
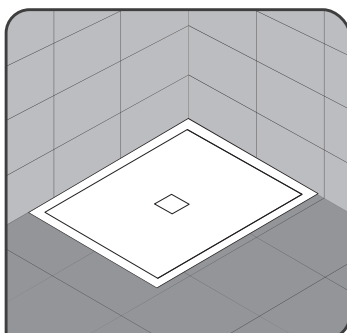

pre-installation

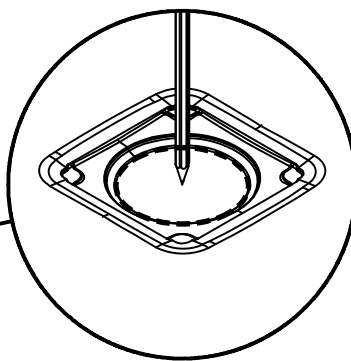
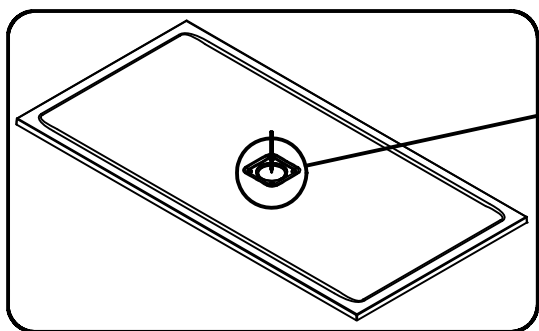

Marcar la ubicación del desagüe y montarlo con el plato para comprobar su correcta ubicación.

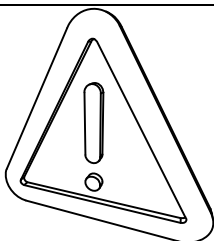
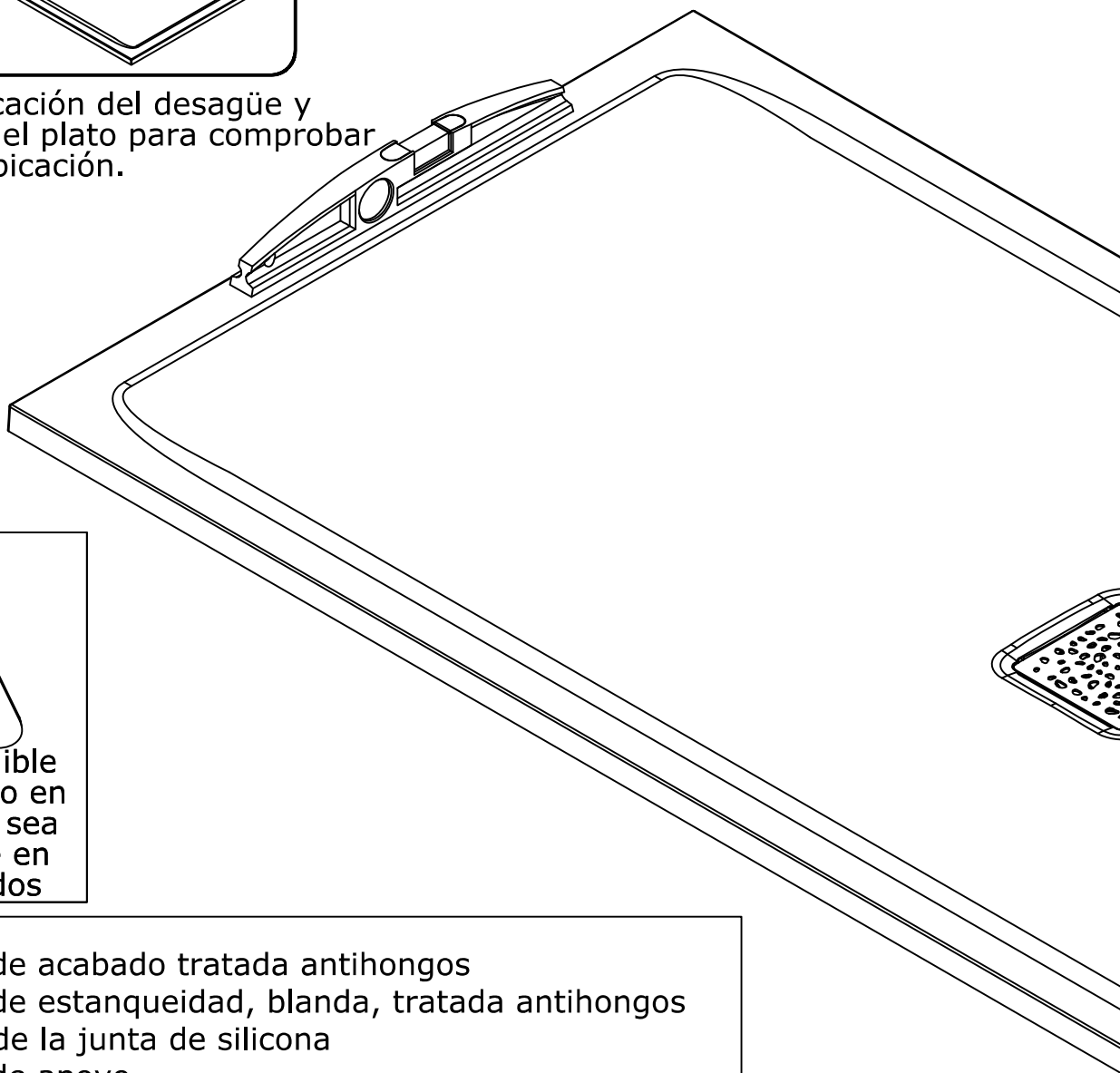

Es imprescindible instalar el plato en una zona que sea imputrescible en todos sus lados

- ① - silicona de acabado tratada antihongos
- ② - silicona de estanqueidad, blanda, tratada antihongos
- ③ - soporte de la junta de silicona
- ④ - silicona de apoyo
- ⑤ - pegamento poliuretano o polímero MS

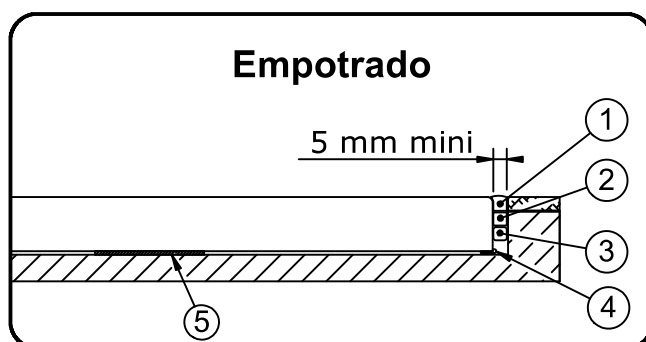
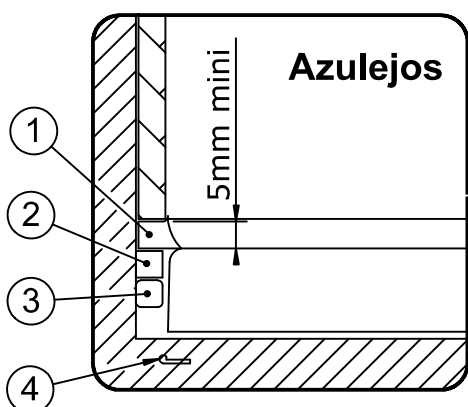



Durante las obras proteger el plato de golpes, quemaduras, rayaduras, etc.



La instalación de un venteo es necesaria si otro aparato está conectado al mismo recorrido de evacuación.

No utilizar ácido clorhídrico o desengrasante potente

### Instalación directa al suelo

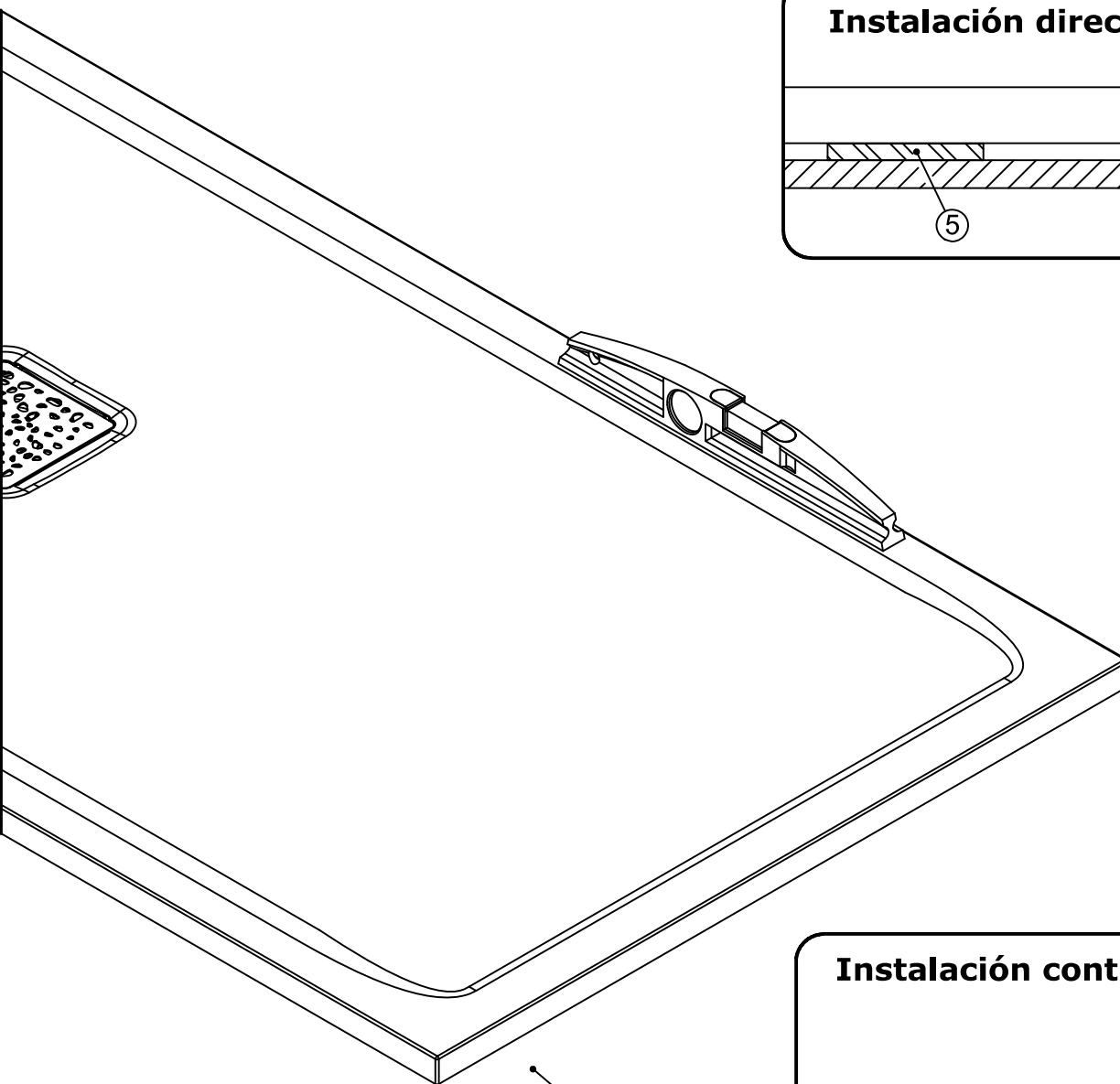
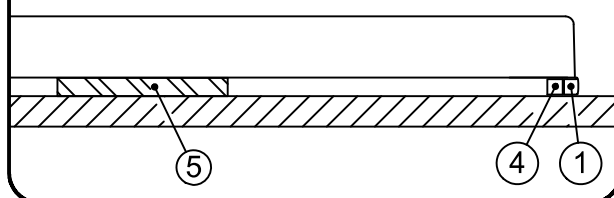

Suelo rígido, plano y seco indispensable

### Instalación contra baldosas

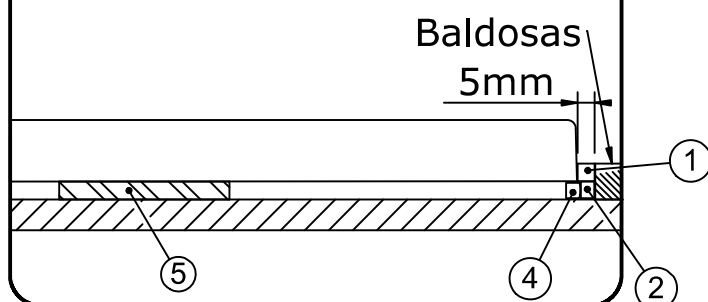

# TIPOS DE INSTALACIÓN KINEMOON

## KINEMOON QUADRADO

### 1. Instalado sobre pies ajustables con revestimiento de baldosas

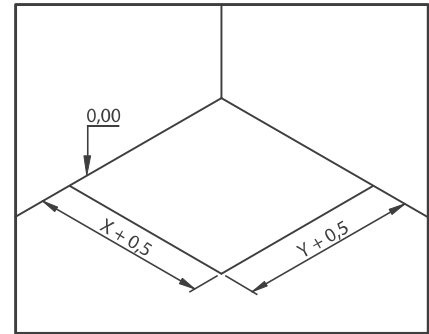
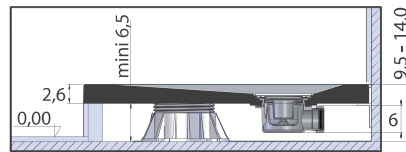

Preparación de la instalación

### 2. Colocación sobre suelo

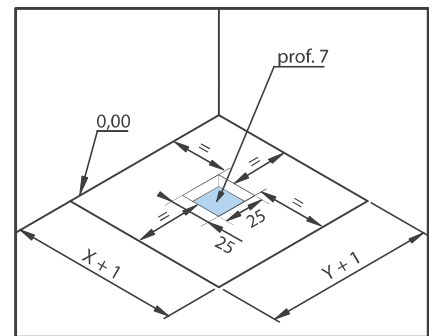
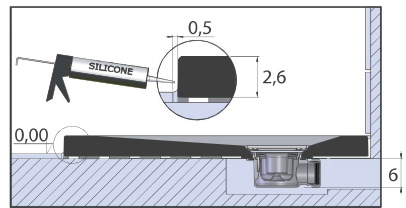
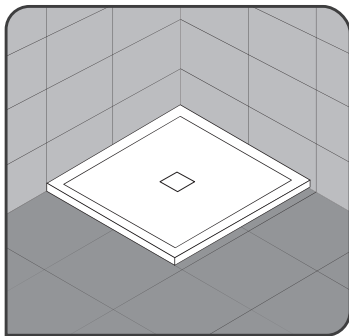

Preparación de la instalación

### 3. Instalación a ras de suelo, colocado sobre pies ajustables

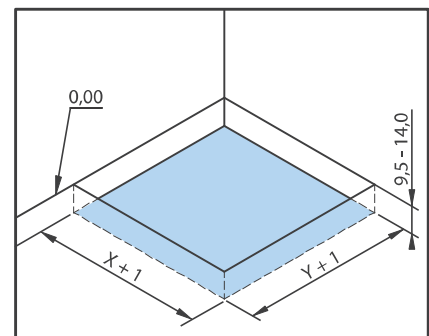
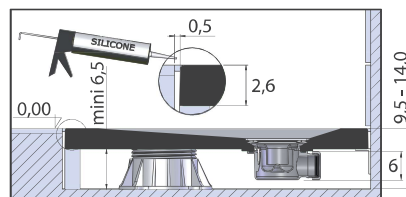

Preparación de la instalación

### 4. Instalación a ras de suelo, sin pies ajustables

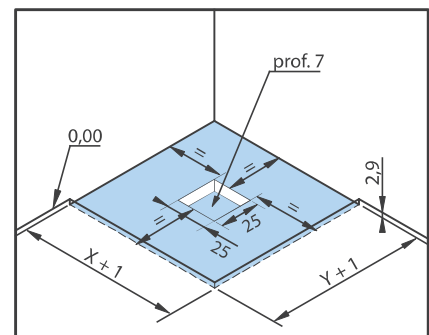
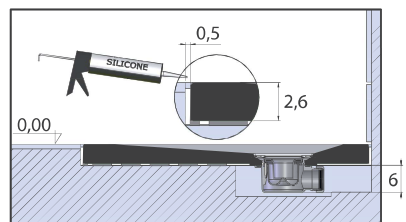
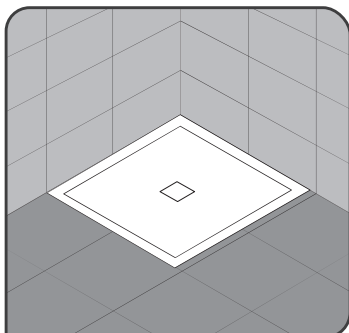

Preparación de la instalación

# TIPOS DE INSTALACIÓN KINEMOON

## KINEMOON RECTANGULARES

### 1. Instalado sobre pies regulables con revestimiento de baldosas

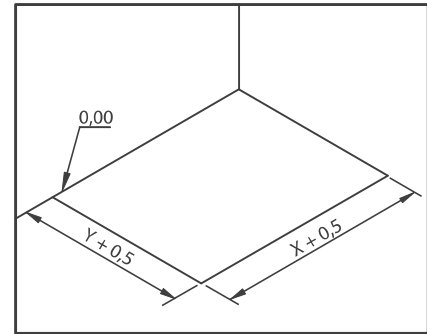
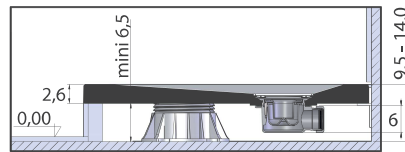

Preparación de la instalación

### 2. Colocación sobre suelo

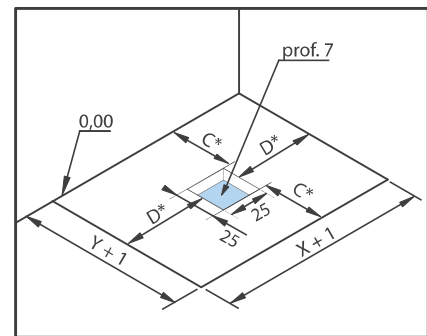
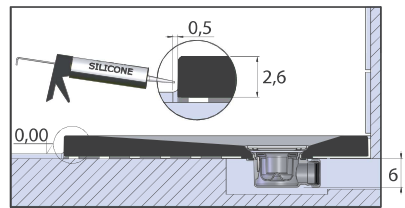
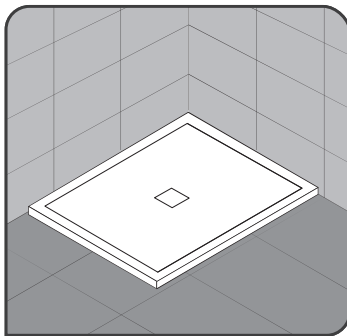

Preparación de la instalación

### 3. Instalación a ras de suelo, colocado sobre pies regulables

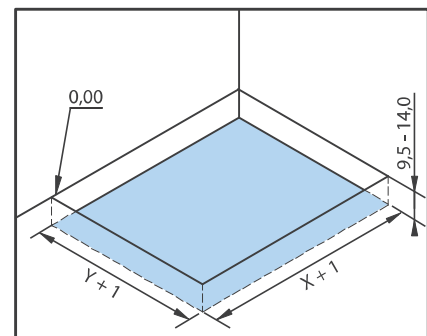
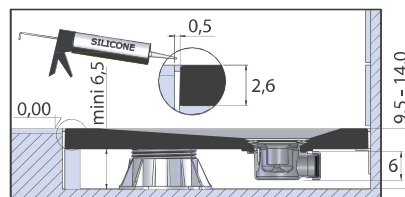

Preparación de la instalación

### 4. Instalación a ras de suelo, sin pies regulables

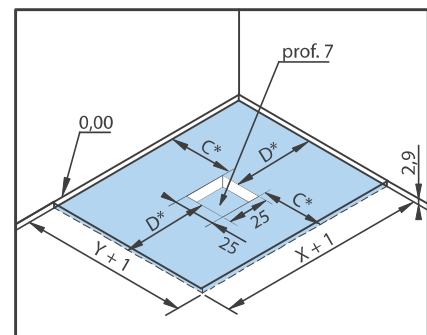
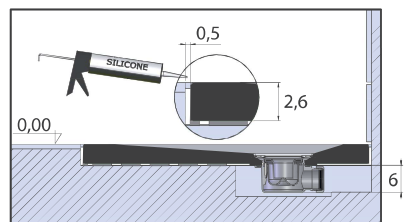
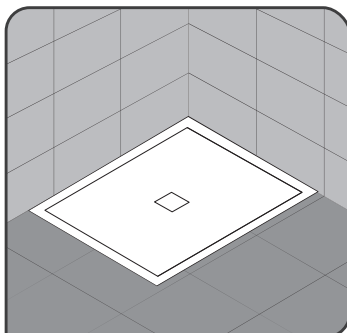

Preparación de la instalación

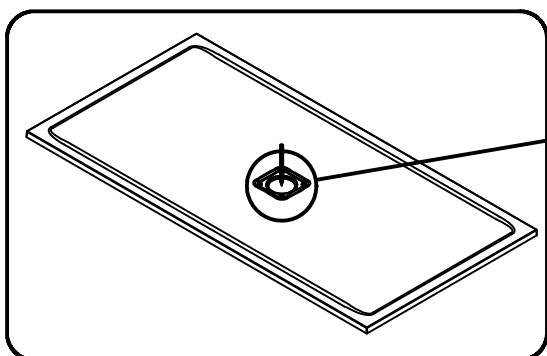

Tracciare la posizione dello scarico e realizzare un montaggio a vuoto dello scarico e del piatto



- ① - silicone di finitura antimuffa 5mm minimo
- ② - silicone di tenuta antimuffa
- ③ - elemento di tenuta del silicone
- ④ - supporte in silicone
- ⑤ - colla poliuretanica o MS polimero

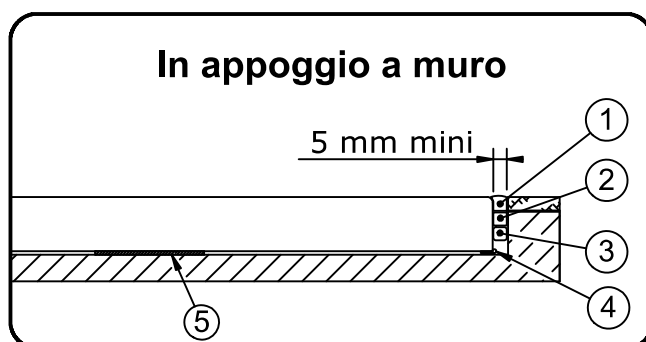
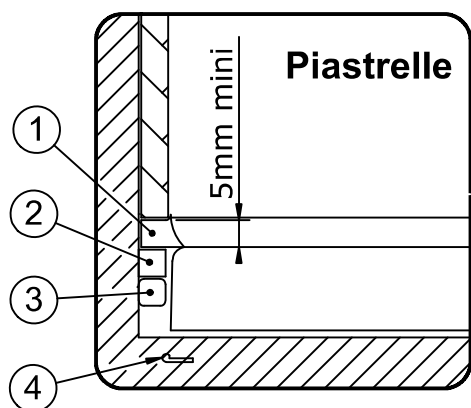



Durante la posa proteggere il piatto da graffi, colpi, attrezzi, bruciature



Il montaggio di una valvola di sicurezza è richiesto per un uso ottimale se un altre utenze sono collegate allo stesso scarico.

Non utilizzare acido cloridrico o forti sgrassatori

### Posa diretta al suolo

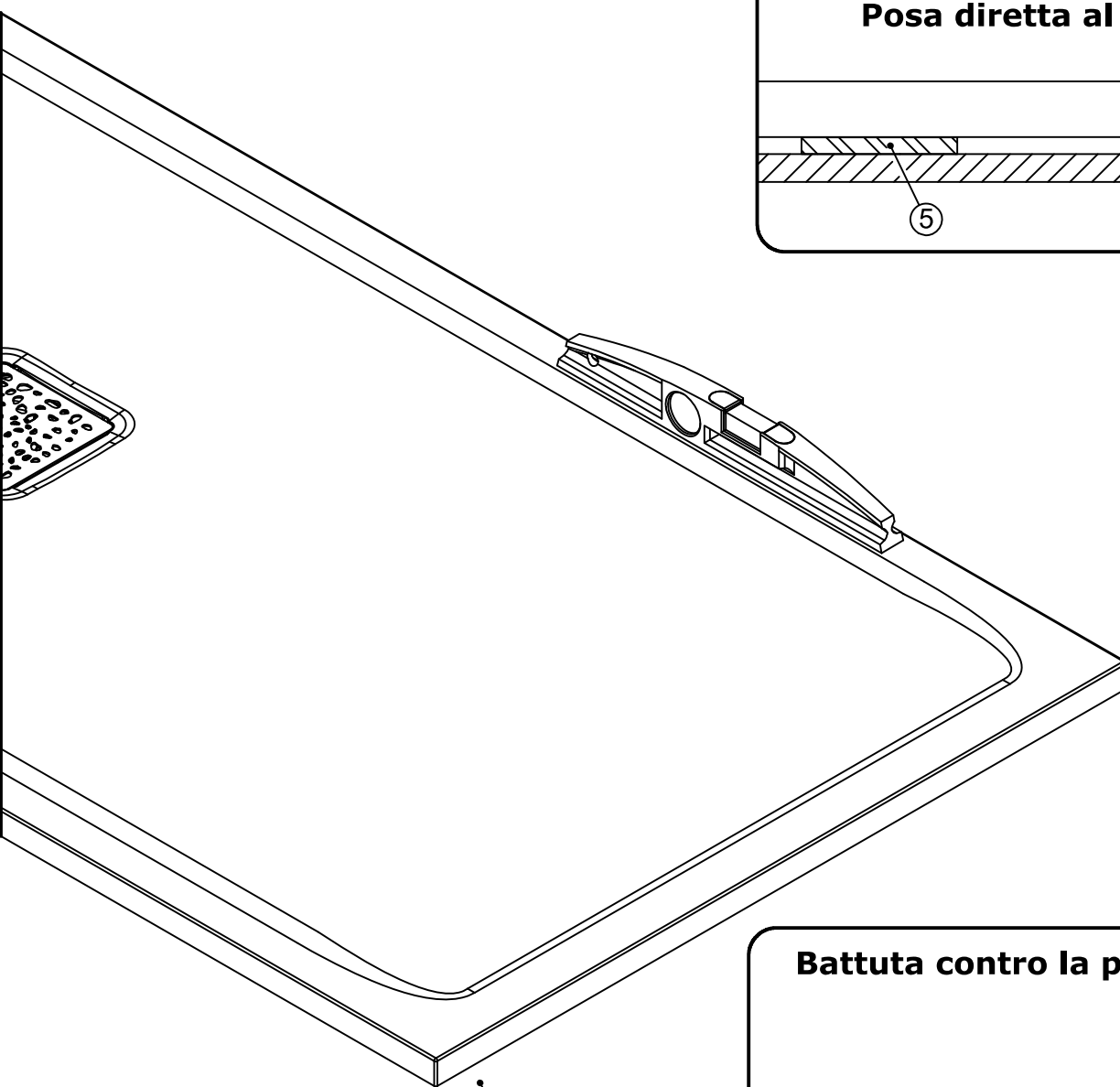

### Battuta contro la piastrella

Piastrella  
5mm

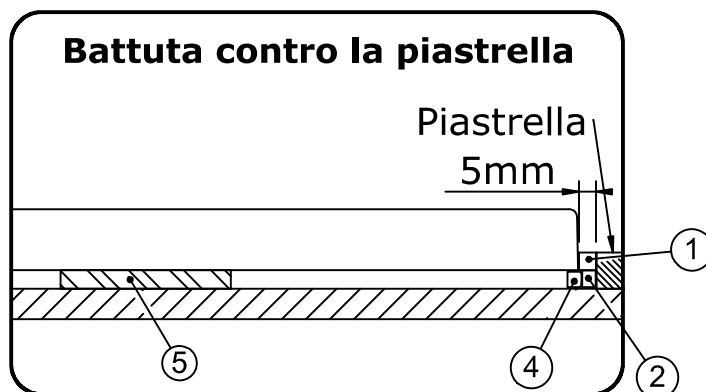

Suolo robusto e non umido

# TIPI DI INSTALLAZIONE DI KINEMOON

## KINEMOON QUADRATO

### 1. Montato su piedini regolabili con rivestimento in piastrelle

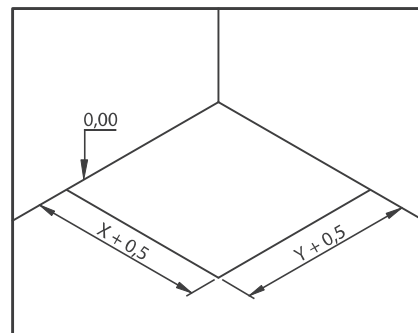
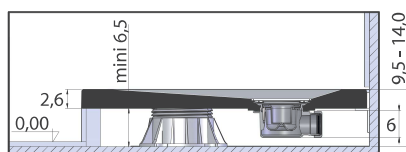

predisposizione impianto

### 2. Installato in appoggio a pavimento

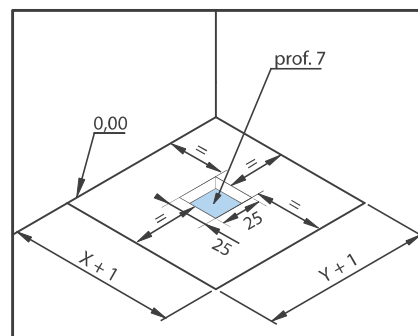
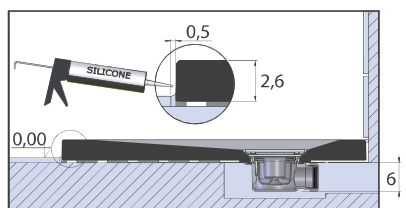
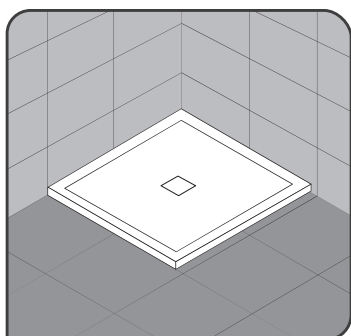

predisposizione impianto

### 3. Incassato e posizionato su piedini regolabili

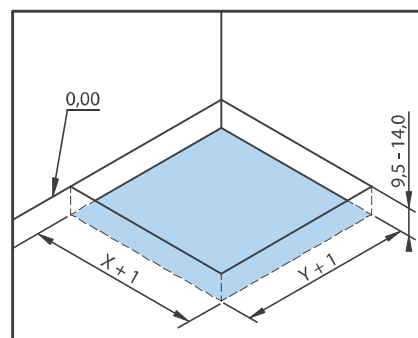
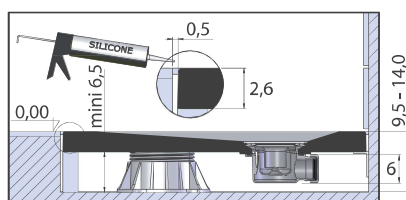

predisposizione impianto

### 4. Installato a filo pavimento

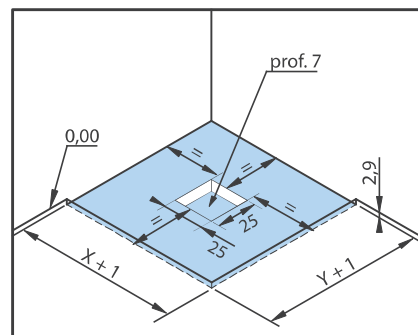
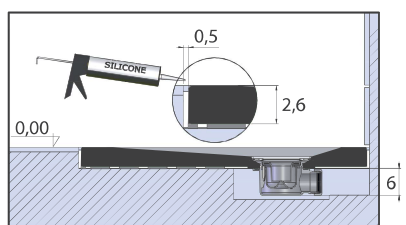
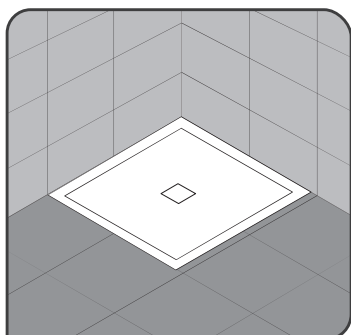

predisposizione impianto

# TIPI DI INSTALLAZIONE DI KINEMOON

## KINEMOON RETTANGOLARE

1. Montato su piedini regolabili con rivestimento in piastrelle

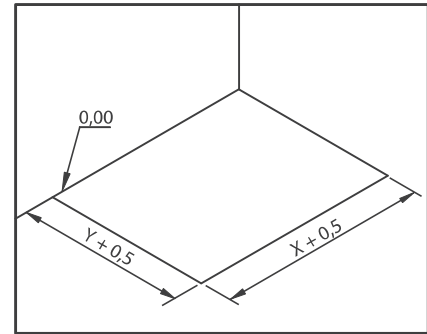
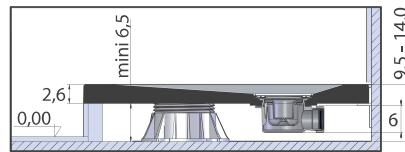

predisposizione impianto

2. Installato in appoggio a pavimento

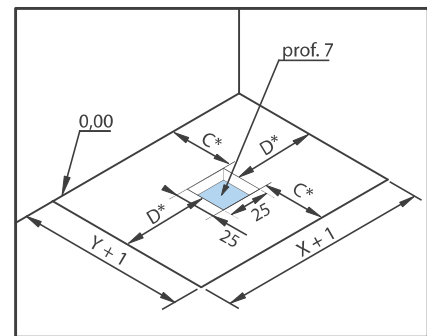
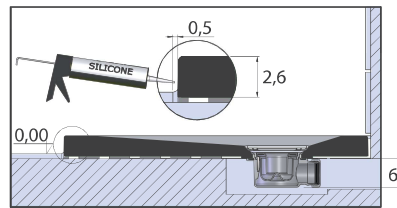
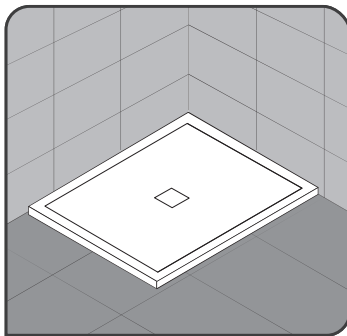

predisposizione impianto

3. Incassato e posizionato su piedini regolabili

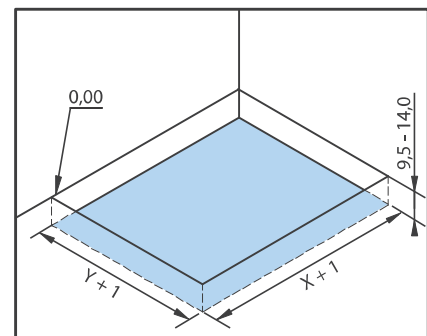
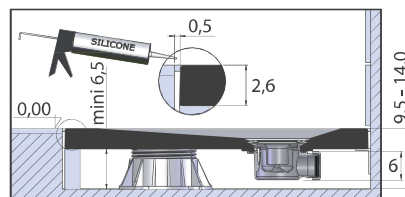

predisposizione impianto

4. Installato a filo pavimento

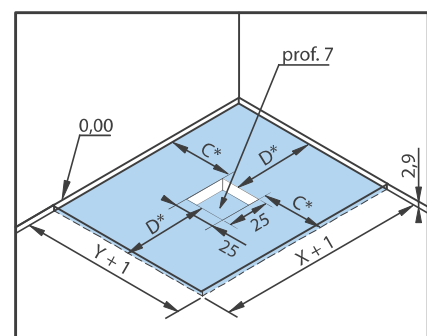
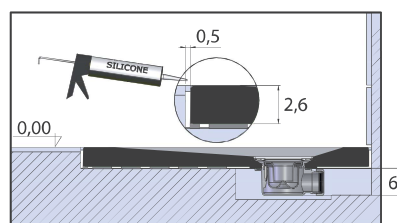
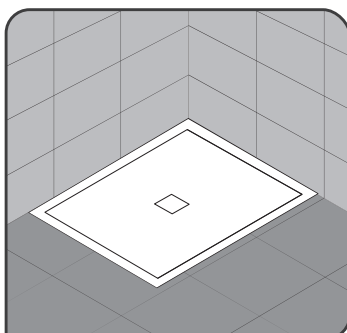

predisposizione impianto

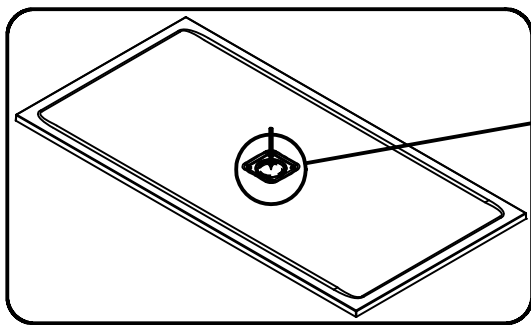

Markeer de positie van de afvoer en  
situeer de afvoer en de douchebak op  
de gewenste plaats



- ① - siliconenafwerking behandeld met een anti-schimmellaag van 5 mm min
- ② - waterdichte siliconenafwerking behandeld met een anti-schimmellaag
- ③ - element ter ondersteuning van de siliconenstrip
- ④ - aanbrengen van siliconenkit
- ⑤ - polyuretaan lijm of MS polymeer

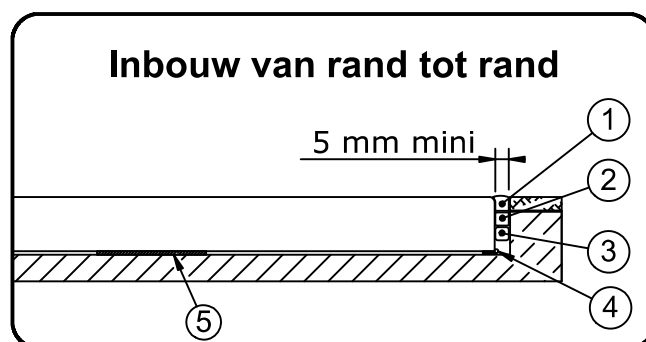
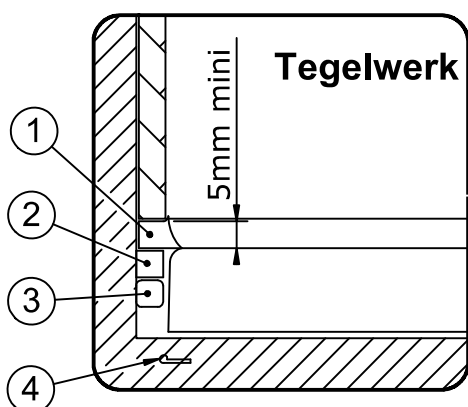



Bescherm de douchebak tijdens de werkzaamheden tegen brandplekken, schokken en beschadigingen door krassen etc



De Montage van een afdichtingsklep/ventiel is noodzakelijk voor optimaal gebruik indien men een ander sanitair product wil aansluiten op dezelfde afvoer.

Geen chloorhoudende producten en ontvetters gebruiken!

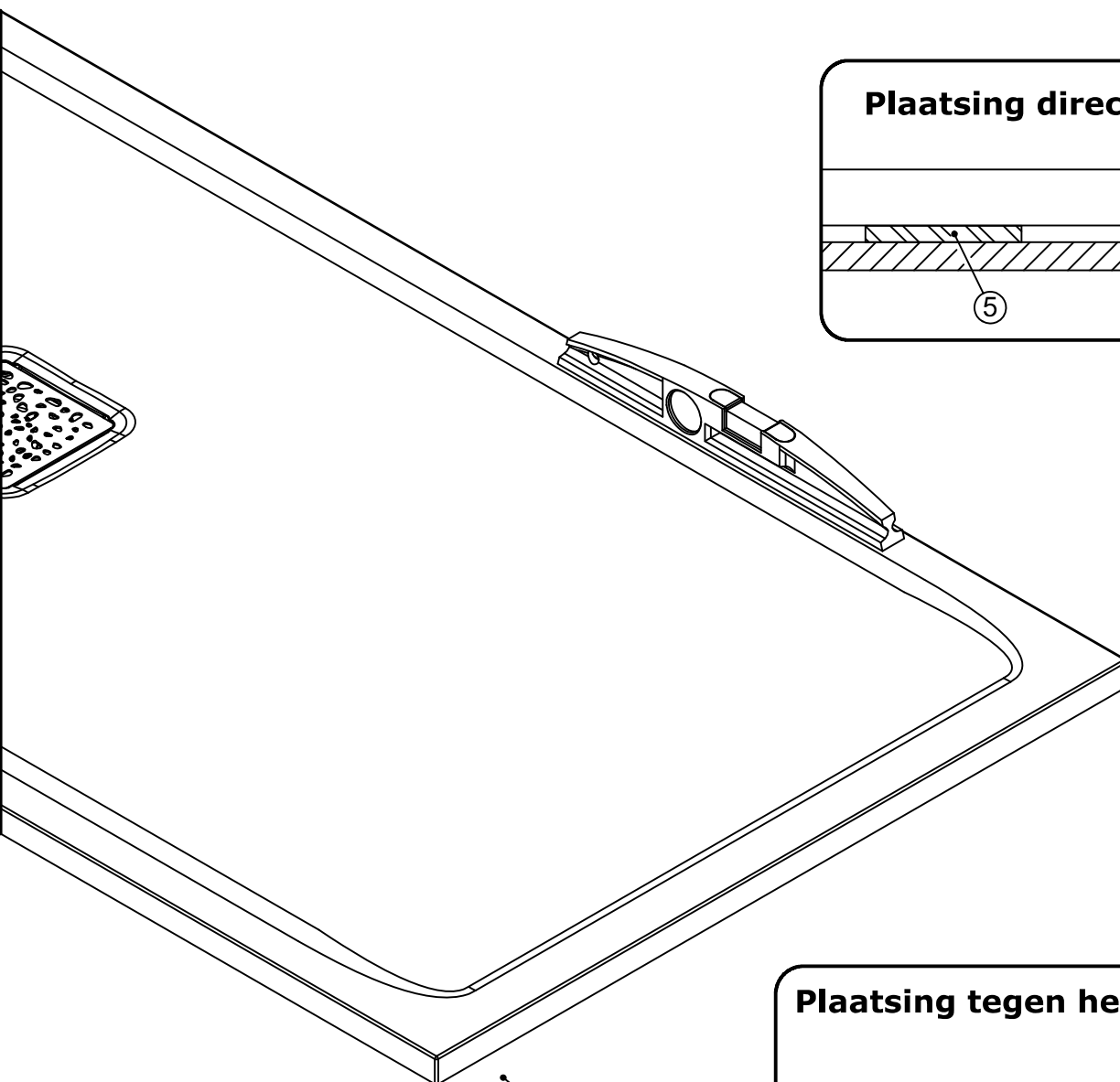

### Plaatsing direct op de vloer

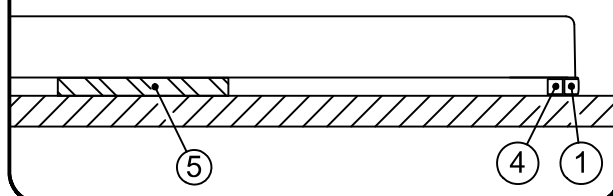

### Plaatsing tegen het tegelwerk

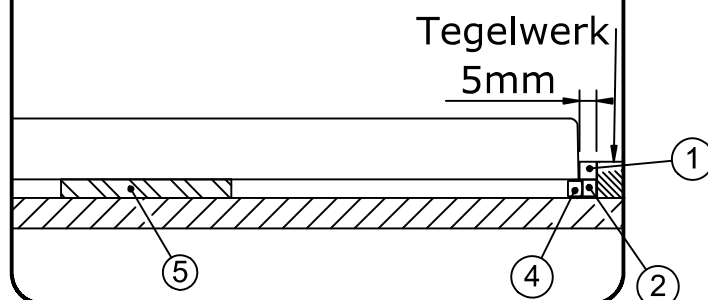

Vlakke niet-vochtige vloer is essentieel

# KINEMOON-INSTALLATIEMOGELIJKHEDEN

## KINEMOON VIERKANT

1. Geïnstalleerd op in hoogte verstelbare poten en afgewerkt met tegels

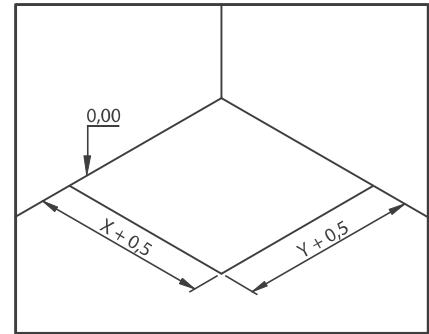
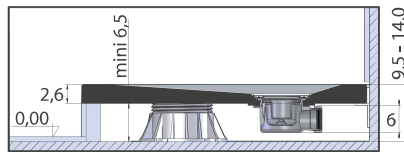

Vorbereitung montage

2. Geïnstalleerd half verzonken tegen de tegels

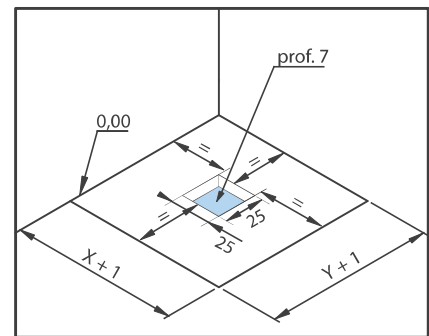
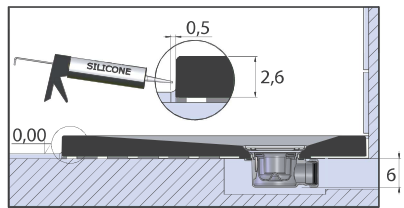
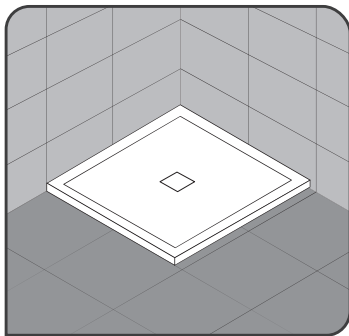

Vorbereitung montage

3. Ingebouwd met in hoogte verstelbare poten

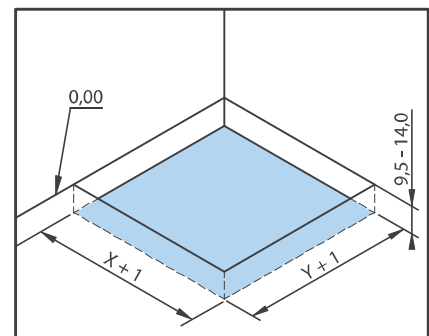
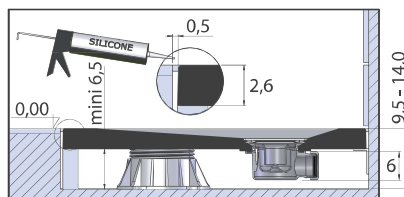

Vorbereitung montage

4. Ingebouwd zonder in hoogte verstelbare poten

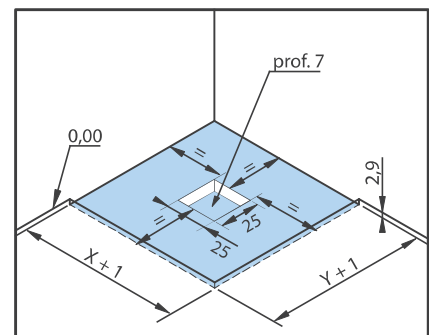
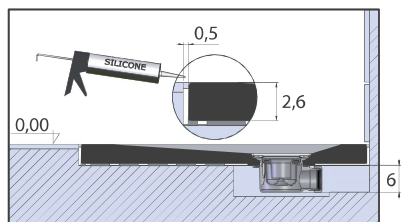
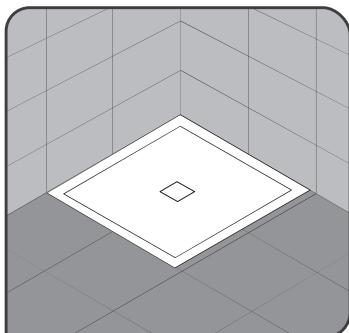

Vorbereitung montage

# KINEMOON-INSTALLATIEMOGELIJKHEDEN

## KINEMOON RECHTHOEKIG

1. Geïnstalleerd op in de hoogte verstelbare poten en afgewerkt met tegels.

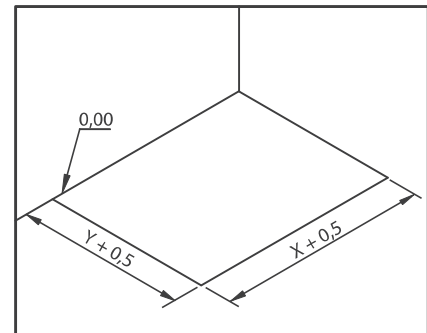
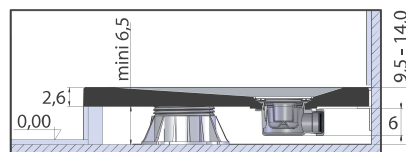

Vorbereitung montage

2. Geïnstalleerd gedeeltelijk verzonken tegen de tegels

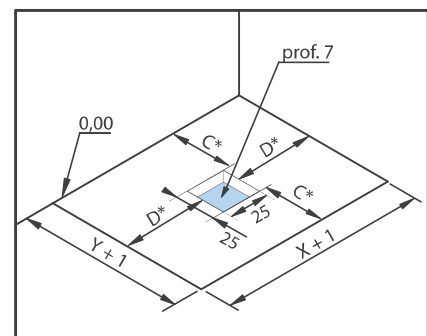
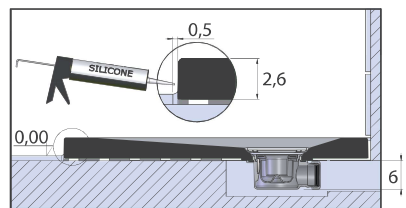
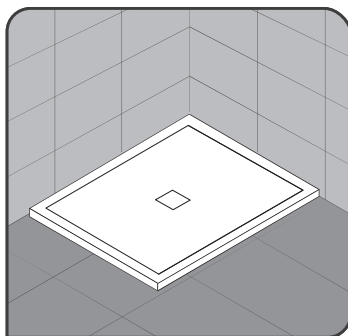

Vorbereitung montage

3. Ingebouwd met in de hoogte verstelbare poten

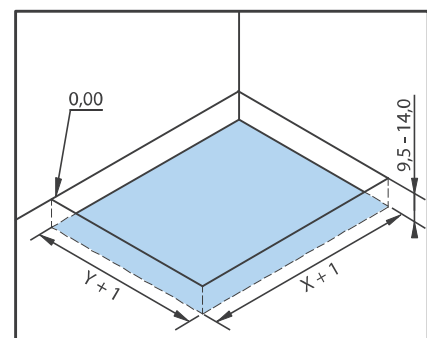
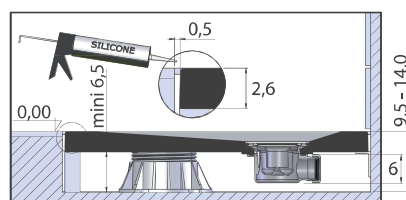

Vorbereitung montage

4. Ingebouwd zonder in hoogte verstelbare poten

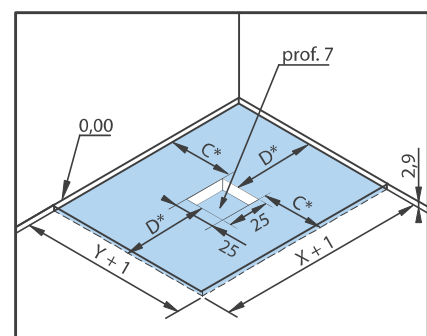
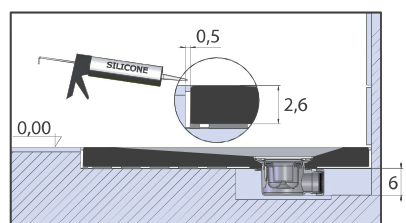
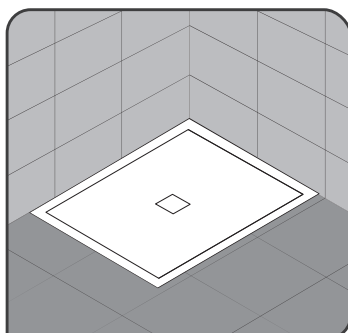

Vorbereitung montage

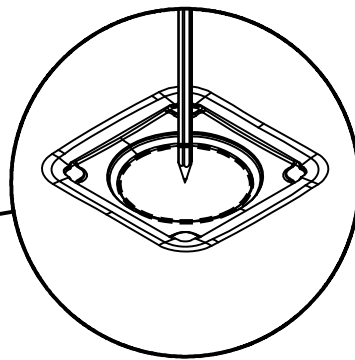
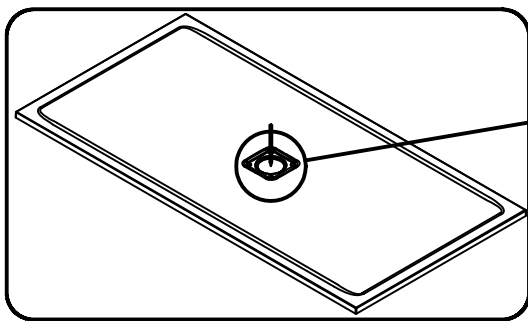
**D**

Position für den Ablauf anzeichnen  
und vormontieren.

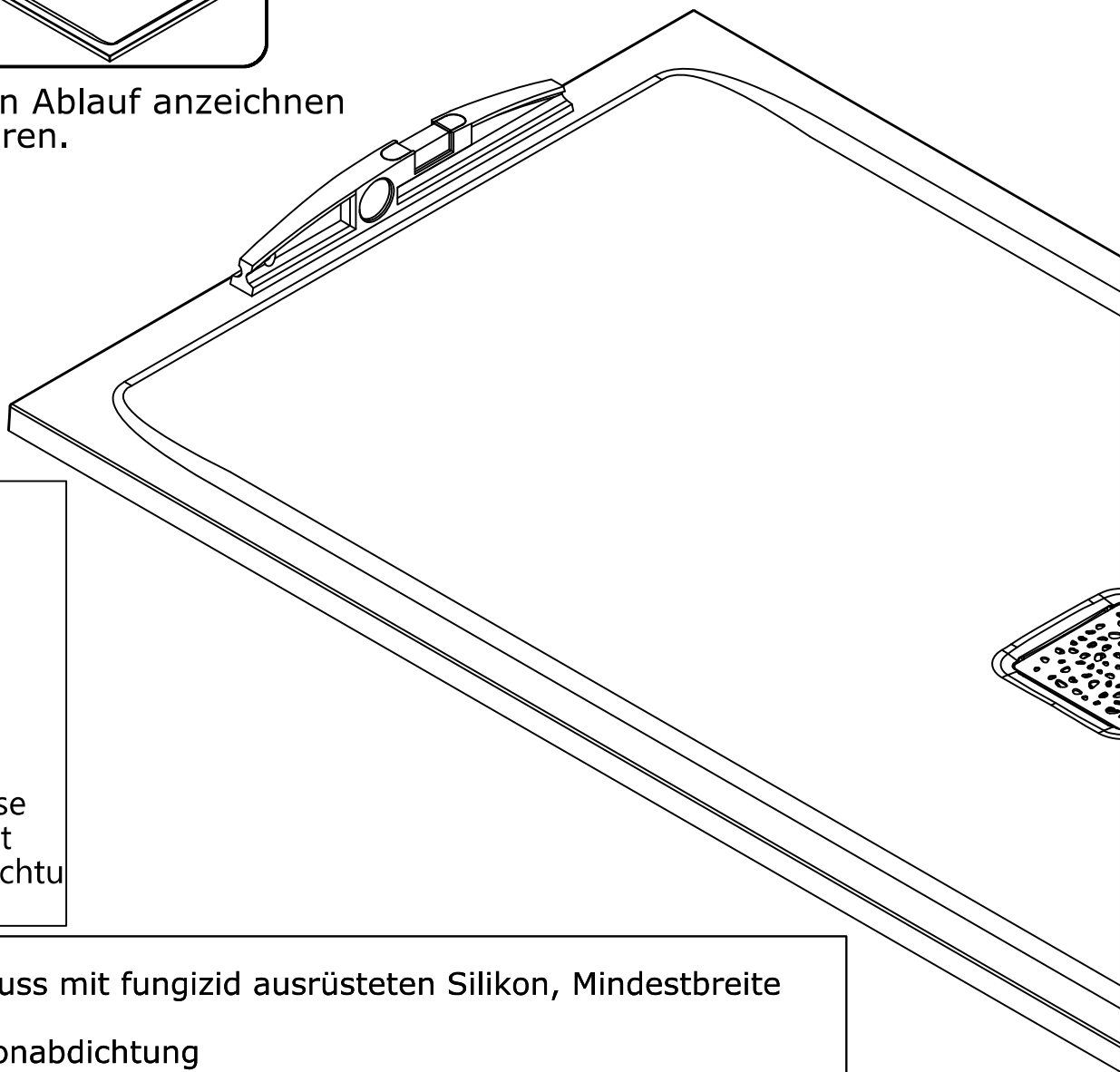

- ① - Fugenabschluss mit fungizid ausgerüsteten Silikon, Mindestbreite von 5 mm
- ② - flexible Silikonabdichtung
- ③ - Träger Element/Unterbau Silikondichtung
- ④ - Silikonträger
- ⑤ - Polyurethan-Klebstoff oder MS-Polymer

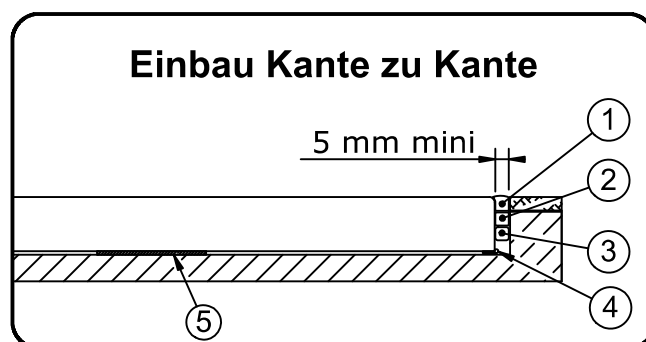
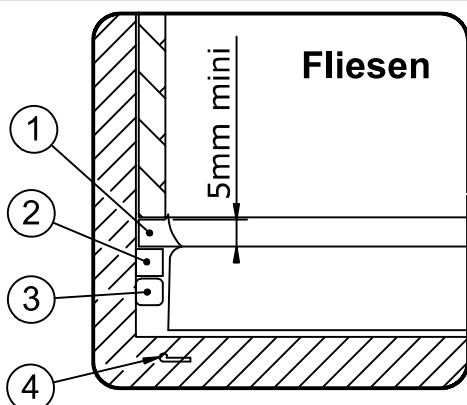



Montage eines Unterdruckventils wird benötigt, wenn eine andere Vorrichtung an den gleichen Ablauf angeschlossen ist.

Während den Installationsarbeiten auf ausreichenden Schutz gegen aggressive Mittel achten: Verbrennungen, Stöße, Kratzer oder Abbeizmittel ...

Verwenden Sie keine säurehaltigen oder andere aggressive Entfetter.

freie Aufstellung auf Fertigfußboden

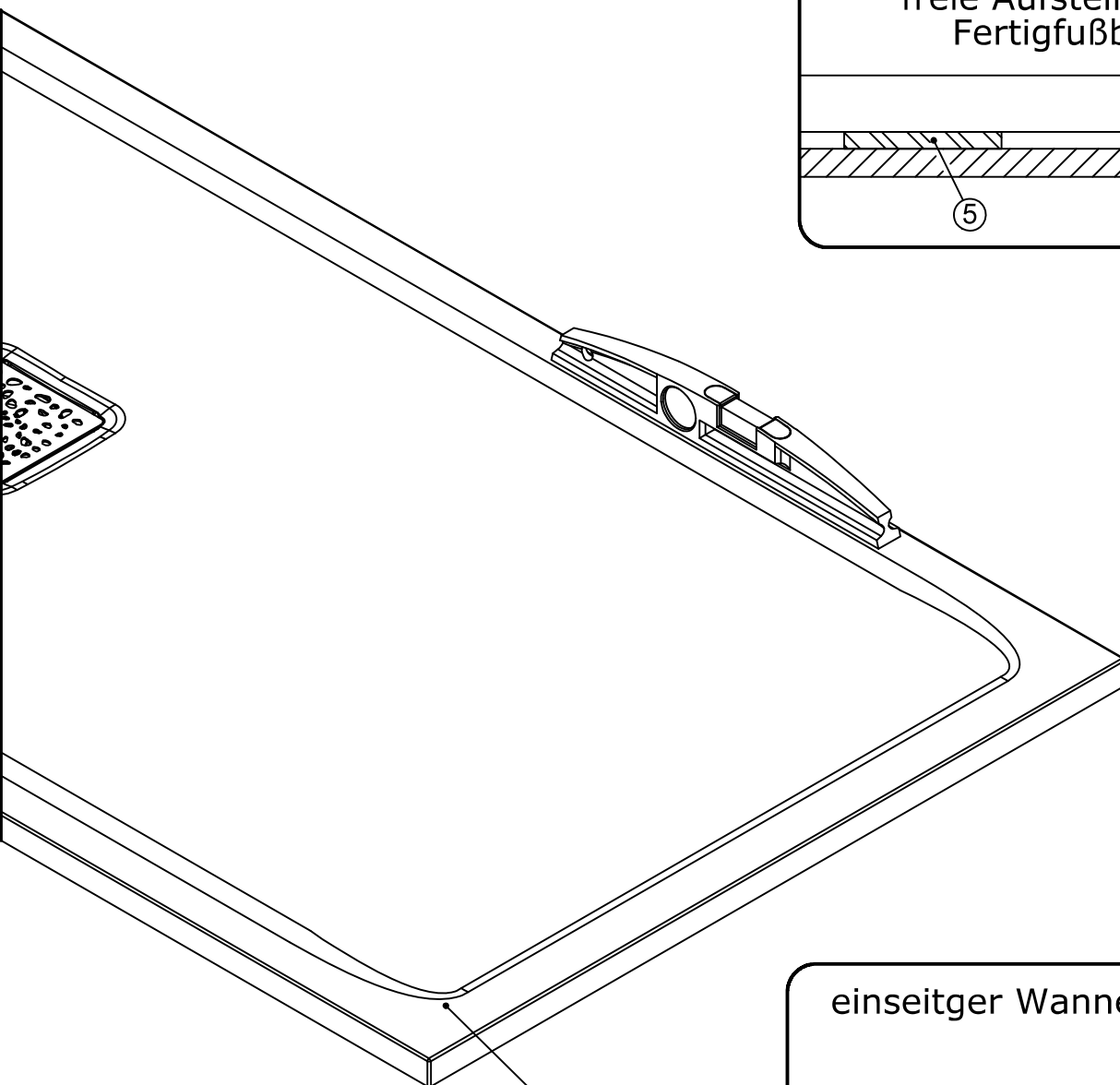
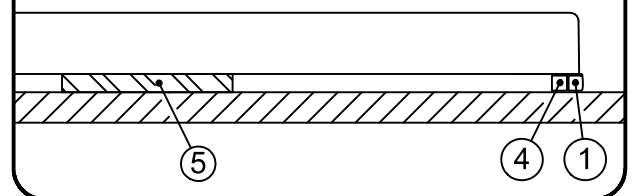

einseitiger Wannenanschluß

Fliesen  
5mm

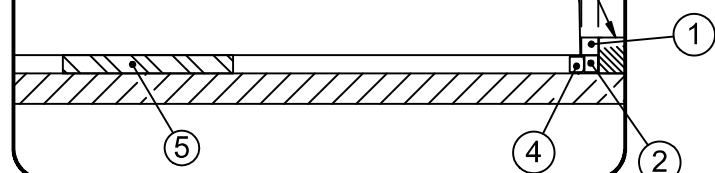

Auf festen, planen und nicht feuchten Boden achten.

# KINEMOON-INSTALLATIONSARTEN

## KINEMOON QUADRAT

### 1. Montage auf Fertigfußboden mit Wannenfüßen und Fliesensockel

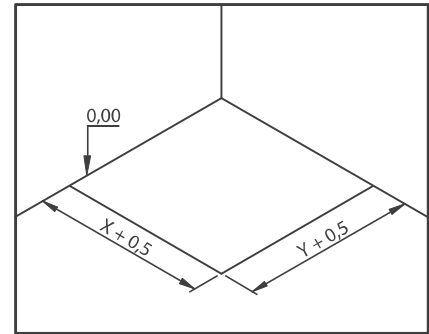
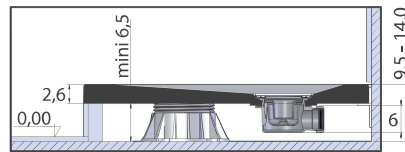

Montagevorbereitung Fertigfußboden mit Wannenfüße

### 2. Wird im Widerlager gegen die Fliese montiert.

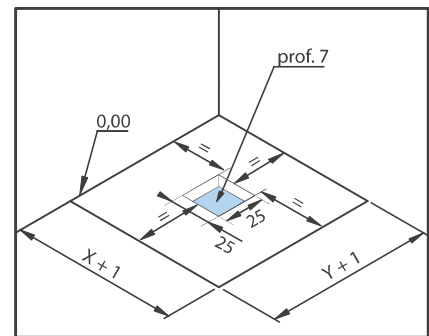
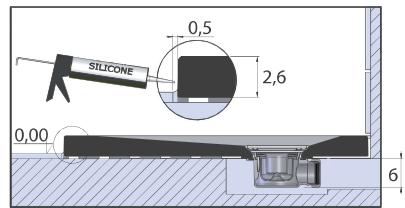
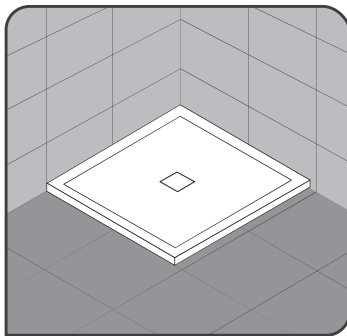

Montagevorbereitung Fertigfußboden mit Wannenfüße

### 3. Bodengleiche Montage mit Wannenfüße

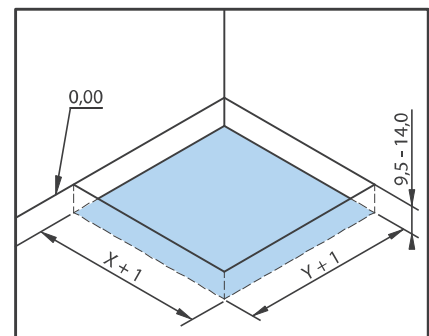
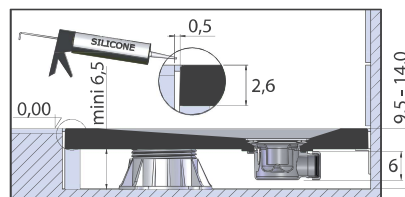

Montagevorbereitung Fertigfußboden mit Wannenfüße

### 4. Bodengleiche Montage ohne Wannenfüße

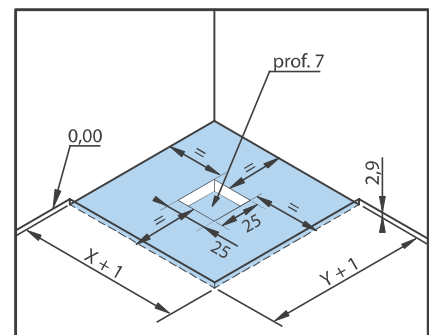
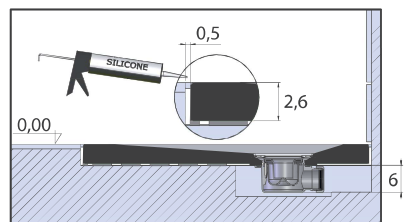
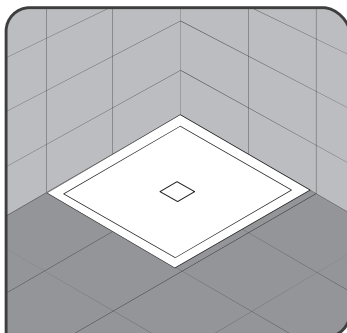

Montagevorbereitung Fertigfußboden mit Wannenfüße

# KINEMOON-INSTALLATIONSARTEN

## KINEMOON RECHTECKIG

1. Montiert auf verstellbaren Füßen mit gefliester Verkleidung

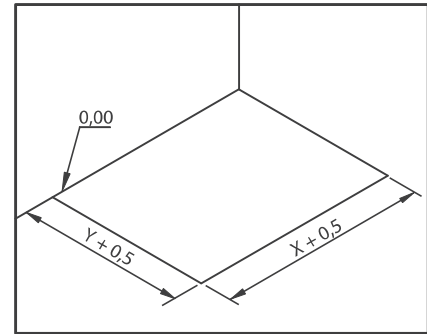
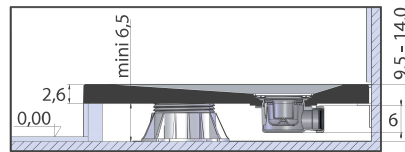

Vorbereitung der Implementierung

2. Wird im Widerlager gegen die Fliese montiert.

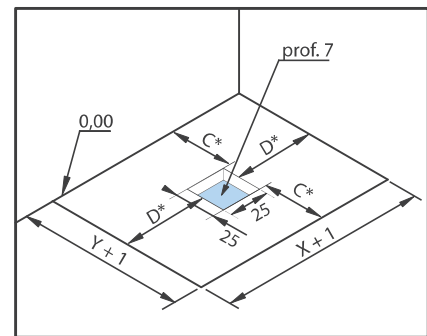
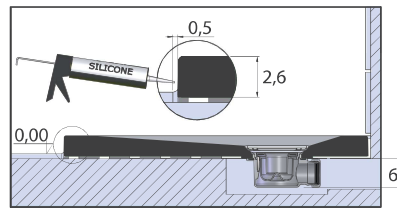
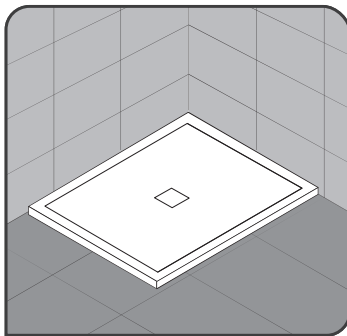

Vorbereitung der Implementierung

3. Eingebaut und auf verstellbaren Füßen platziert

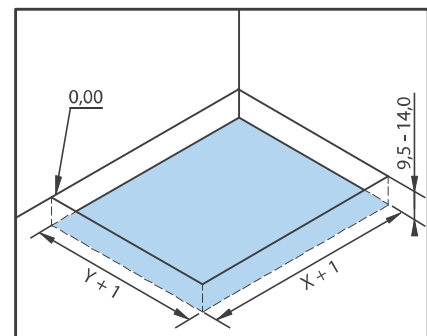
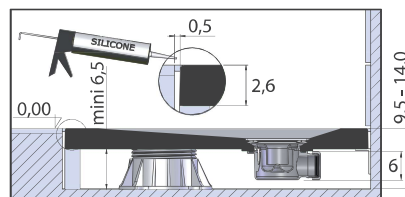

Vorbereitung der Implementierung

4. Eingebaut und installiert ohne Stellfüße

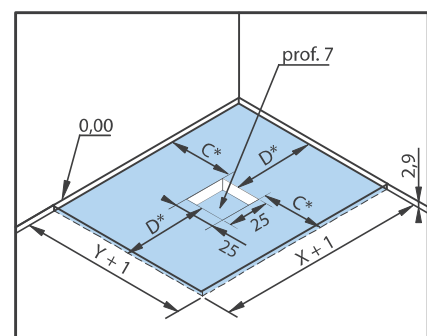
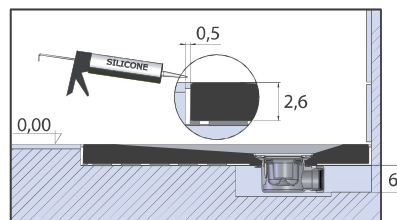
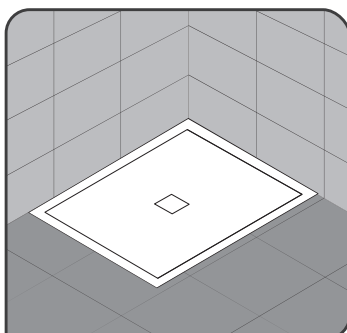

Vorbereitung der Implementierung

- F Mise en place des plots de colle polyuréthane ou MS polymère
- GB Loading the plots glue polyurethane or MS polymer
- E Ubicacion de los puntos de pegamento poliuretano o polimero MS
- I Posizione dei punti di colla poliuretanoica o MS polimero
- NL Breng de polyuretaan lijm of MS polymeer aan op de juiste plaats
- D Bringen Sie den Polyurethan-/MS-Polymere-Kleber auf

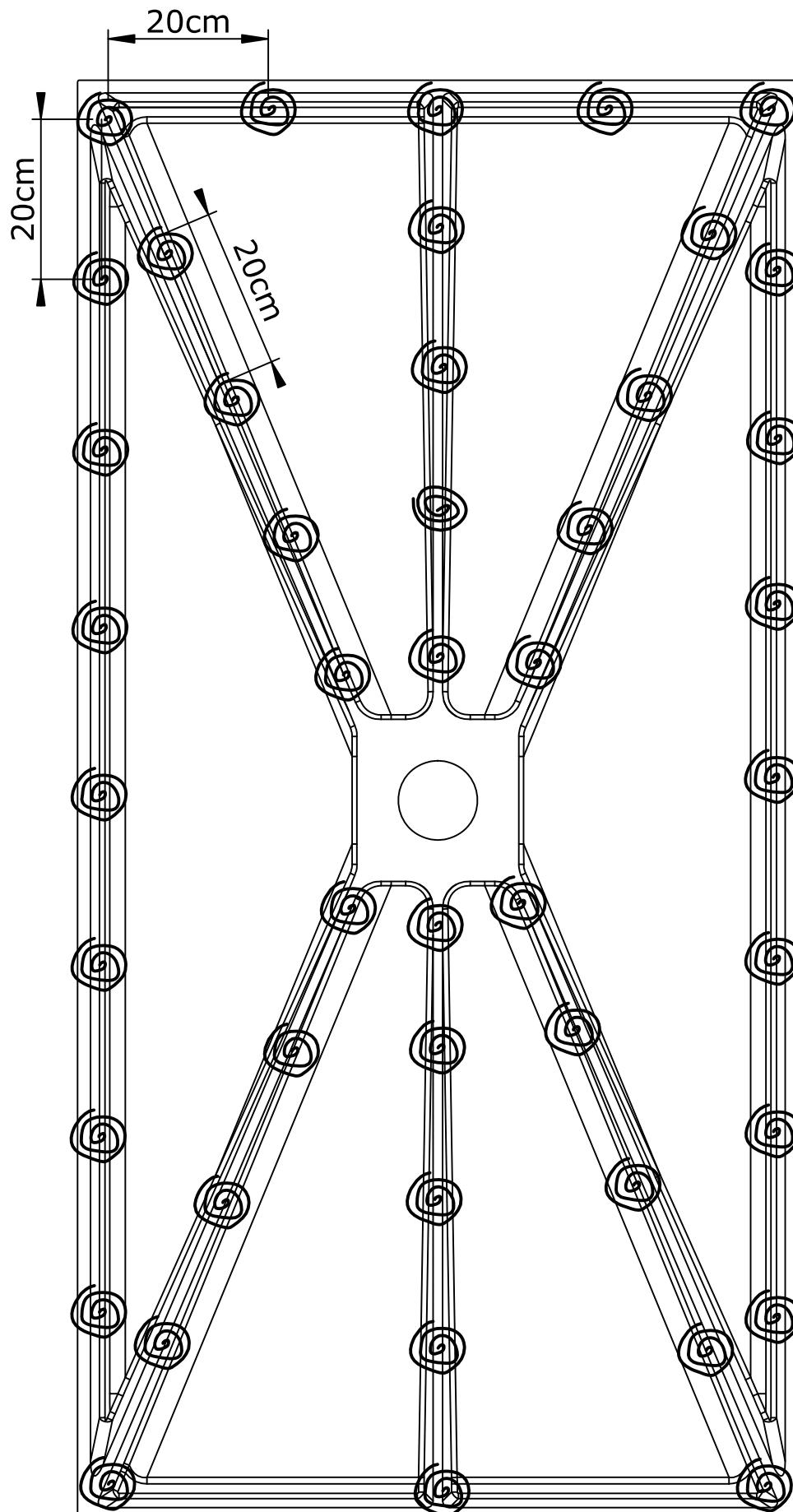



24h

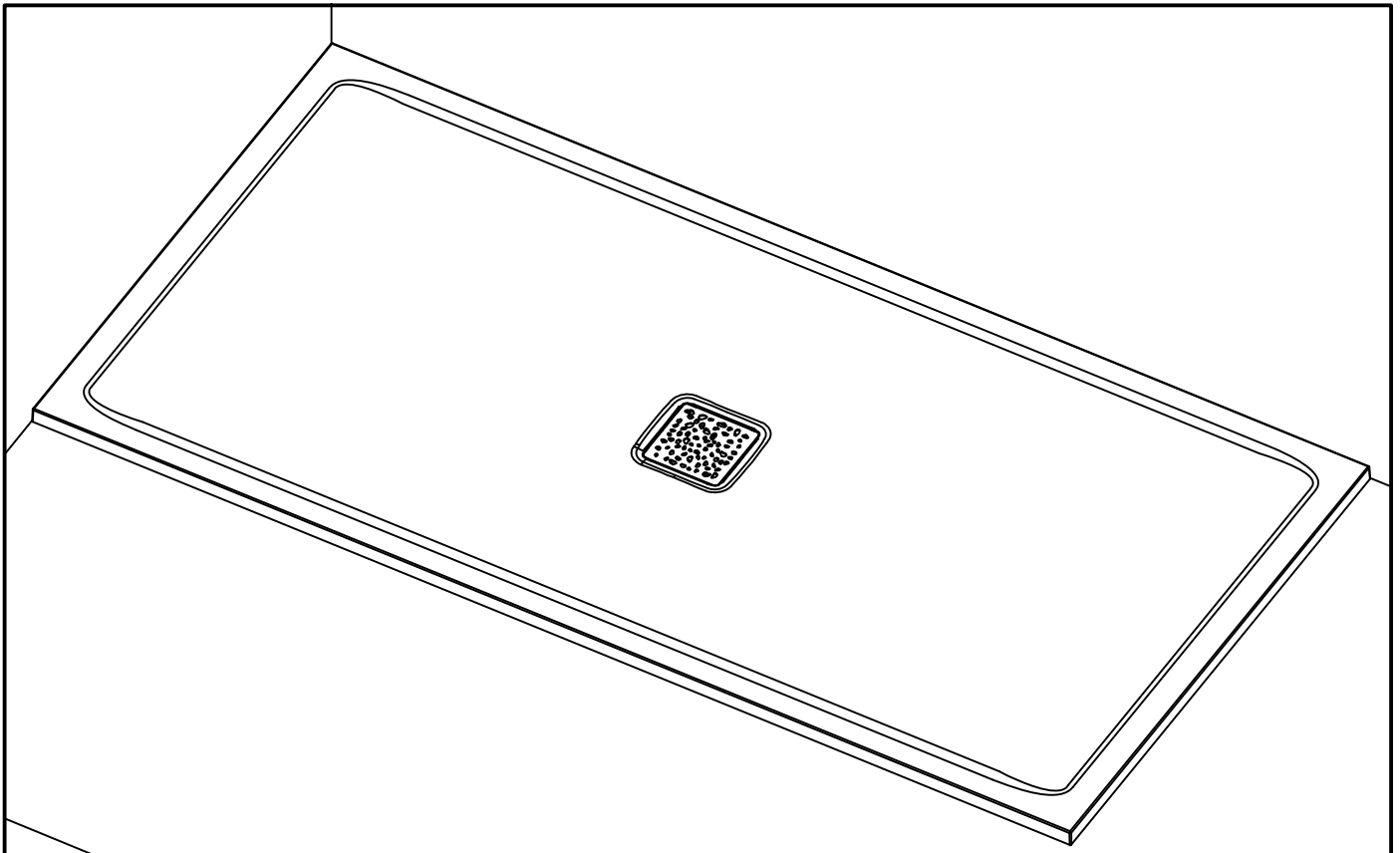



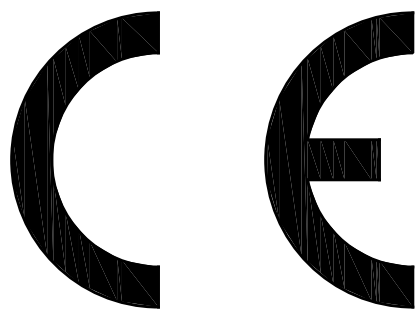

AQUAPRODUCTION, Site industriel,  
F - 44680 Chaumes-en-Retz

19

**EN 14527 - CL2**

Aptitude au nettoyage : satisfaisant

Durabilité : satisfaisant



**SAV**  
**SERVICE HELPLINES**  
**ASSISTENZA POST-VENDITA**  
**SERVICIO POSTVENTA**

**FRANCE**

02 40 21 29 45

**UK**

020 8842 0033

**IRELAND**

04697 33102

**DEUTSCHLAND**

+49 (0) 6074 / 30928 0

**ITALIA**

(0382) 6181

**OSTEREICH**

+43 1 710 60 70

**SCHWEIZ**

(01) 748 17 44

**ESPANA**

93 544 60 76

**NEDERLAND**

+31 475 487 100

**BELGIE**

+31 475 487 100

**BELGIQUE**

+31 475 487 100

**РОССИЯ**

963 19 40, 773 67 22